

## 2" Cast Iron Butterfly Valve | Lug Style EPDM Seat, Gear Operated

Cast iron lug style butterfly valve with nickel plated ductile iron disc and EPDM seat.

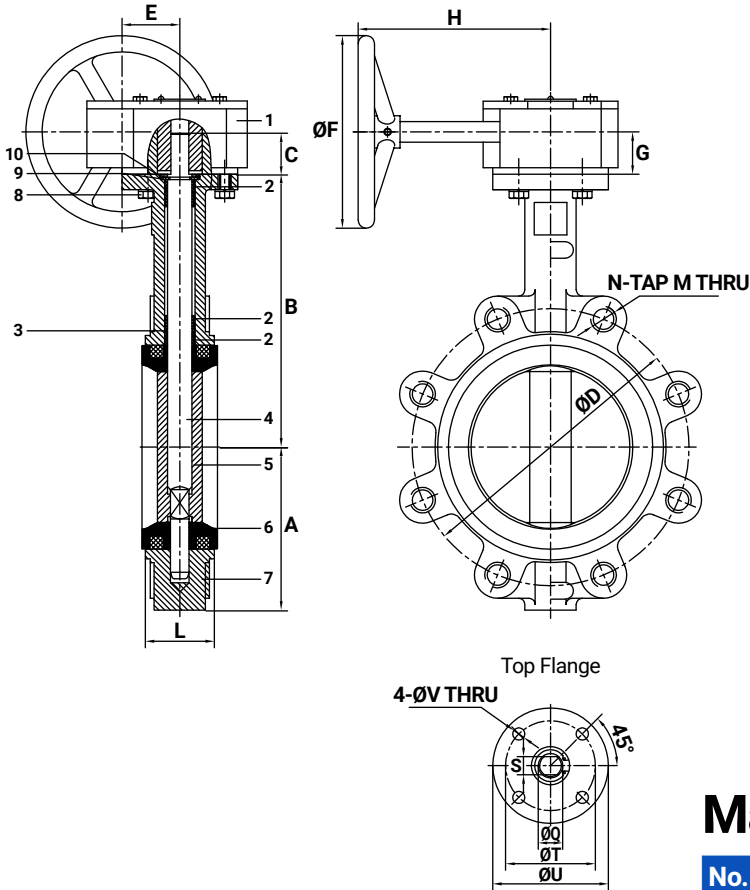

<b>Size</b>	2"
<b>Body Material</b>	Cast Iron
<b>Body Design</b>	Lug Type
<b>Operation</b>	Gearbox
<b>Connections</b>	Flange / ANSI 125
<b>Pressure Rating</b>	225 PSI
<b>Temperature Rating</b>	-4° to 194° F
<b>Length (End to End)</b>	1.7"
<b>Weight</b>	16 lbs

### Features

- Gearbox operator is self-locking in any position for throttle control
- Fusion-Bonded Epoxy Coating
- Does not require flange gaskets thanks to EPDM seat

### Materials List

No.	Part Name	Material	No.	Part Name	Material
1	Gear Operator	DI, Carbon Steel, CI	6	Seat	EPDM
2	Bushing	PTFE	7	Body	Cast Iron
3	O-Ring	EPDM	8	Bolt	Stainless Steel
4	Stem	SS416	9	Thrust Clip	Carbon Steel
5	Disc	Ductile Iron	10	Circlip	Carbon Steel

### Dimensions

Size	A	B	C	Class 150		E	ØF	G	H	ØQ	L	S	ØT	ØU	ØV															
in.	in.	mm	in.	mm	in.	mm	in.	mm	in.	mm	in.	mm	in.	mm	in.	mm														
2"	3	76	6 <sup>3</sup> / <sub>8</sub>	162	1 <sup>1</sup> / <sub>4</sub>	32	4 <sup>3</sup> / <sub>4</sub>	121	5 <sup>7</sup> / <sub>8</sub> "-10 UNC	4	1 <sup>3</sup> / <sub>4</sub>	44	5 <sup>5</sup> / <sub>16</sub>	135	1 <sup>1</sup> / <sub>8</sub>	28	5 <sup>1</sup> / <sub>2</sub>	139	1 <sup>1</sup> / <sub>2</sub>	12.7	1 <sup>1</sup> / <sub>8</sub>	42	3 <sup>3</sup> / <sub>8</sub>	10	2 <sup>3</sup> / <sub>4</sub>	70	3 <sup>3</sup> / <sub>16</sub>	90	3 <sup>3</sup> / <sub>8</sub>	9.5
3"	3 <sup>3</sup> / <sub>4</sub>	95	7 <sup>7</sup> / <sub>8</sub>	181	1 <sup>1</sup> / <sub>4</sub>	32	6	152	5 <sup>7</sup> / <sub>8</sub> "-10 UNC	4	1 <sup>3</sup> / <sub>4</sub>	44	5 <sup>5</sup> / <sub>16</sub>	135	1 <sup>1</sup> / <sub>8</sub>	28	5 <sup>1</sup> / <sub>2</sub>	139	1 <sup>1</sup> / <sub>2</sub>	12.7	1 <sup>1</sup> / <sub>4</sub>	45	3 <sup>3</sup> / <sub>8</sub>	10	2 <sup>3</sup> / <sub>4</sub>	70	3 <sup>3</sup> / <sub>16</sub>	90	3 <sup>3</sup> / <sub>8</sub>	9.5
4"	4 <sup>1</sup> / <sub>2</sub>	114	7 <sup>7</sup> / <sub>8</sub>	200	1 <sup>1</sup> / <sub>4</sub>	32	7 <sup>1</sup> / <sub>2</sub>	191	5 <sup>7</sup> / <sub>8</sub> "-10 UNC	8	1 <sup>3</sup> / <sub>4</sub>	44	5 <sup>5</sup> / <sub>16</sub>	135	1 <sup>1</sup> / <sub>8</sub>	28	5 <sup>1</sup> / <sub>2</sub>	139	5 <sup>5</sup> / <sub>8</sub>	15.88	2 <sup>1</sup> / <sub>16</sub>	52	1 <sup>1</sup> / <sub>2</sub>	12	2 <sup>3</sup> / <sub>4</sub>	70	3 <sup>3</sup> / <sub>16</sub>	90	3 <sup>3</sup> / <sub>8</sub>	9.5
6"	5 <sup>1</sup> / <sub>2</sub>	139	8 <sup>7</sup> / <sub>8</sub>	225	1 <sup>1</sup> / <sub>4</sub>	32	9 <sup>1</sup> / <sub>2</sub>	241	3 <sup>4</sup> / <sub>4</sub> "-10 UNC	8	1 <sup>3</sup> / <sub>4</sub>	44	5 <sup>5</sup> / <sub>16</sub>	135	1 <sup>1</sup> / <sub>8</sub>	28	5 <sup>1</sup> / <sub>2</sub>	139	3 <sup>4</sup> / <sub>4</sub>	19.05	2 <sup>3</sup> / <sub>16</sub>	56	9 <sup>1</sup> / <sub>16</sub>	14	2 <sup>3</sup> / <sub>4</sub>	70	3 <sup>3</sup> / <sub>16</sub>	90	3 <sup>3</sup> / <sub>8</sub>	9.5
8"	7	177	10 <sup>1</sup> / <sub>4</sub>	260	1 <sup>1</sup> / <sub>2</sub>	38	11 <sup>1</sup> / <sub>4</sub>	298	3 <sup>4</sup> / <sub>4</sub> "-10 UNC	8	2 <sup>1</sup> / <sub>16</sub>	62	10 <sup>13</sup> / <sub>16</sub>	275	1 <sup>1</sup> / <sub>16</sub>	40	8 <sup>1</sup> / <sub>16</sub>	211	7 <sup>1</sup> / <sub>8</sub>	22.23	2 <sup>3</sup> / <sub>16</sub>	60	1 <sup>1</sup> / <sub>16</sub>	17	4	102	4 <sup>19</sup> / <sub>16</sub>	125	7 <sup>1</sup> / <sub>16</sub>	11.5
10"	8	203	11 <sup>1</sup> / <sub>2</sub>	292	1 <sup>1</sup> / <sub>2</sub>	38	14 <sup>1</sup> / <sub>4</sub>	362	7 <sup>8</sup> / <sub>8</sub> "-9 UNC	12	2 <sup>1</sup> / <sub>16</sub>	62	10 <sup>13</sup> / <sub>16</sub>	275	1 <sup>1</sup> / <sub>16</sub>	40	8 <sup>1</sup> / <sub>16</sub>	211	1 <sup>1</sup> / <sub>8</sub>	28.58	2 <sup>3</sup> / <sub>16</sub>	66	7 <sup>1</sup> / <sub>8</sub>	22	4	102	4 <sup>19</sup> / <sub>16</sub>	125	7 <sup>1</sup> / <sub>16</sub>	11.5
12"	9 <sup>1</sup> / <sub>2</sub>	242	13 <sup>1</sup> / <sub>4</sub>	337	1 <sup>1</sup> / <sub>2</sub>	38	17	432	7 <sup>8</sup> / <sub>8</sub> "-9 UNC	12	3 <sup>1</sup> / <sub>16</sub>	78	10 <sup>13</sup> / <sub>16</sub>	275	1 <sup>1</sup> / <sub>16</sub>	40	8 <sup>1</sup> / <sub>16</sub>	220	1 <sup>1</sup> / <sub>4</sub>	31.75	3 <sup>3</sup> / <sub>16</sub>	77	1 <sup>1</sup> / <sub>16</sub>	24	4	102	4 <sup>19</sup> / <sub>16</sub>	125	7 <sup>1</sup> / <sub>16</sub>	11.5