

## 4" Cast Iron Wafer Check Valve Dual Plate

Dual plate wafer check valve with EPDM seat, epoxy coated cast iron body, and nickel plated ductile iron discs.

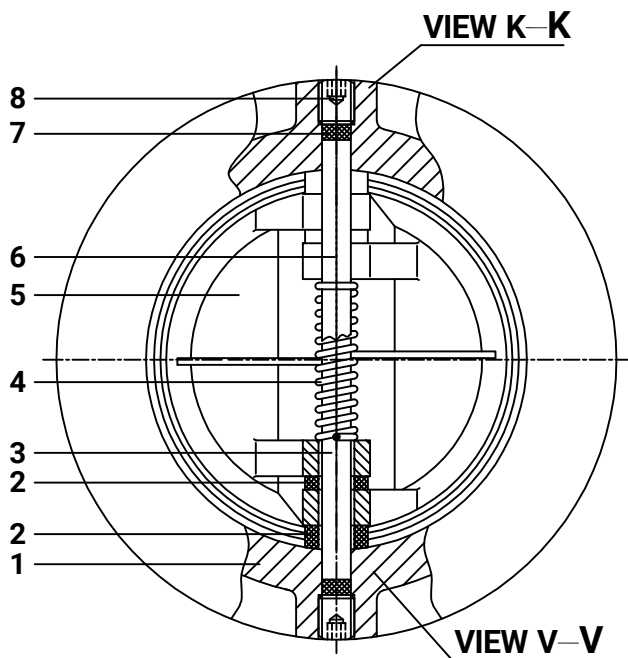
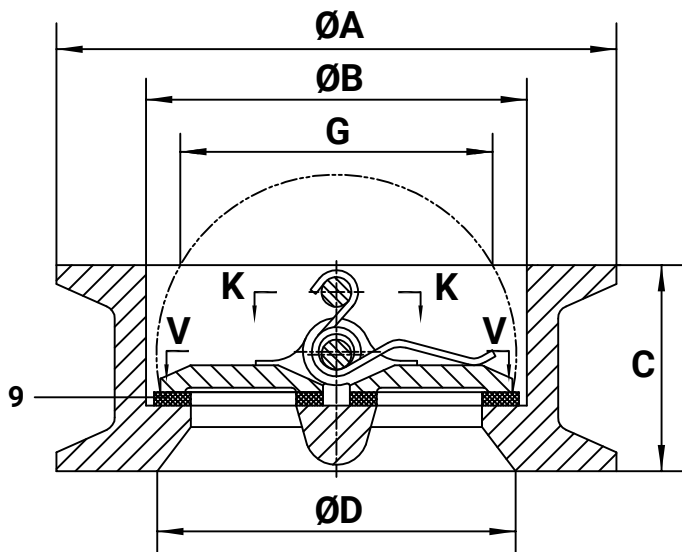

<b>Size</b>	4"
<b>Mechanism</b>	Dual Swing Plates (Spring Loaded)
<b>Connections</b>	Flange / ANSI 125/150
<b>Pressure Rating</b>	150 PSI
<b>Length (End to End)</b>	2.5"
<b>Weight</b>	9 lbs

### Features

- Compact wafer design can be installed in tight spaces
- Can be mounted horizontally or vertically
- Fusion-Bonded Epoxy Coating

### Materials List

No.	Part Name	Material
1	Body	Cast Iron
2	Washer	PTFE
3	Lower Shaft	SS410
4	Spring	SS304
5	Disc	Ductile Iron
6	Upper Shaft	SS410
7	Seal Washer	EPDM
8	Thread Plug	Carbon Steel
9	Seat	EPDM

### Dimensions

Size	A		B		C		D		G	
in.	in.	mm	in.	mm	in.	mm	in.	mm	in.	mm
2"	4 <sup>1</sup> / <sub>8</sub>	105	2 <sup>7</sup> / <sub>16</sub>	65	1 <sup>1</sup> / <sub>16</sub>	43	2 <sup>3</sup> / <sub>16</sub>	59	1 <sup>9</sup> / <sub>16</sub>	20
3"	5 <sup>3</sup> / <sub>8</sub>	137	3 <sup>1</sup> / <sub>16</sub>	94	2 <sup>1</sup> / <sub>2</sub>	64	3 <sup>1</sup> / <sub>2</sub>	88	3	76
4"	6 <sup>3</sup> / <sub>8</sub>	175	4 <sup>5</sup> / <sub>8</sub>	117	2 <sup>1</sup> / <sub>2</sub>	64	4 <sup>5</sup> / <sub>8</sub>	110	3 <sup>3</sup> / <sub>16</sub>	97
6"	8 <sup>3</sup> / <sub>4</sub>	222	6 <sup>1</sup> / <sub>16</sub>	170	3	76	6 <sup>1</sup> / <sub>16</sub>	170	5 <sup>1</sup> / <sub>16</sub>	145
8"	11	279	8 <sup>1</sup> / <sub>16</sub>	224	3 <sup>1</sup> / <sub>2</sub>	89	8 <sup>3</sup> / <sub>4</sub>	222	7 <sup>5</sup> / <sub>8</sub>	193
10"	13 <sup>3</sup> / <sub>8</sub>	340	10 <sup>7</sup> / <sub>16</sub>	265	4 <sup>1</sup> / <sub>2</sub>	114	10 <sup>3</sup> / <sub>8</sub>	264	9 <sup>7</sup> / <sub>16</sub>	239
12"	16 <sup>1</sup> / <sub>8</sub>	410	12 <sup>3</sup> / <sub>16</sub>	310	4 <sup>1</sup> / <sub>2</sub>	114	12 <sup>3</sup> / <sub>16</sub>	310	10 <sup>3</sup> / <sub>16</sub>	259