

# **OPERATOR'S MANUAL**

## **Models WRT/E-4 & WRT/E-5**

### **Serial Number 570,100+**

700 South Schrader Avenue  
P.O. Box 290  
Havana, IL 62644  
Phone (309)543-4425

[www.kifco.com](http://www.kifco.com)

193-0192-2

# Introduction

## Thank you for purchasing a Kifco Water-Reel!

Please read this manual carefully to learn how to operate and service your Water-Reel properly before operating your machine for the first time. Failure to do so can result in personal injury and/or property damage.

If you have any problems or are unclear regarding any of the instructions contained herein, contact your local dealer or Kifco prior to operation.

Record the model & serial number of your machine in a safe location. Should you ever require product support assistance from our factory; the process will be much quicker if you have this information available.

This manual is a permanent part of your Water-Reel and should always be available for reference by the operator. This manual should remain with the Water-Reel at all times. Additional copies of this manual are available on our website at [www.kifco.com](http://www.kifco.com).

## Measurements

In this manual all measurements are in U.S. SAE units unless otherwise noted.

## Warranty

A standard Kifco Water-Reel warranty is provided. Please see the specific warranty statement in this manual for full details. Neither Kifco Dealers nor their representatives are authorized to make exceptions to any warranty policy. Any deviations from the standard warranty require written authorization from Kifco, Inc.

The warranty specifically excludes:

- Alterations or modifications to any part of your new machine not previously approved by Kifco in writing.
- Irrigation tube that is longer, larger in diameter, or made from non-approved materials will void the warranty on the entire machine.
- Damage caused by normal wear, accident, lack of reasonable care and maintenance, neglect or abuse.
- Transportation, mailing, service call, diagnostic costs.
- Labor for repairs is also excluded unless unusual circumstances exist and then only if pre-approved.

**Current Parts & Operator's Manuals are always available online at [www.kifco.com](http://www.kifco.com).**

# Table of Contents

<b>Safety</b>	<b>4</b>
<b>Safety Decals</b>	<b>5</b>
<b>Safety Precautions</b>	<b>6-7</b>
<b>Turbine Drive Controls</b>	<b>8</b>
<b>Handling the Polyethylene Tube</b>	<b>9</b>
<b>Water-Reel Start-Up &amp; Operation</b>	<b>10-20</b>
<b>Water Application Rate &amp; Travel Speed</b>	<b>21</b>
<b>Adjustments</b>	<b>22-25</b>
<b>Polyethylene Tube Repair</b>	<b>26</b>
<b>Repair &amp; Maintenance</b>	<b>27-28</b>
<b>Winterizing and Storage</b>	<b>28</b>
<b>Booster Pump Operating Instructions</b>	<b>29-30</b>
<b>Specifications</b>	<b>31</b>
<b>Warranty</b>	<b>32</b>
<b>Notes</b>	<b>33</b>
<b>Dealer Checklist</b>	<b>34</b>

# Safety

## Owner's Responsibilities

The owner is responsible for the safe operation of this product. The important safeguards and instructions appearing in this manual are not meant to cover all possible conditions and situations that may occur. Common sense and caution should be used at all times by all operators to prevent damage or injury to the operator.

The owner is responsible for:

- Reading and understanding this manual. If any instructions remain unclear contact your local dealer or Kifco for further instructions.
- Operating the machine strictly according to prescribed limitations.
- Properly training others who may be permitted to operate the machine.
- Heed the rules of safety, including but not limited to those in these instructions.
- Exercising good judgment relating to safe operation and safe conduct by operators and spectators whether invited or not.
- Always bringing the safety decals and placards on the machine to the attention of operators and spectators.
- **Keeping all shields and guards in place!**

## Read and Heed The Special Messages!

This safety alert symbol is used to indicate messages related to safety. When you see this safety symbol, obey the safety message to avoid personal injury, property damage, or both.



A **“Caution”** message in this manual or on a machine placard means that you could be injured and/or equipment or property may be damaged if you do not follow instructions.

A **“Warning”** message in this manual or on a machine placard means that a hazard exists that could result in severe personal injury or death.

A **“Danger”** message in this manual or on a machine placard means that a hazard exists that will result in severe personal injury or death.

# Safety Decals

All Water Reels are supplied with a variety of safety decals. These decals must be properly maintained, including replacing any that become illegible or are missing. When replacing safety decals, make sure to install them into the correct location as outlined in this manual.

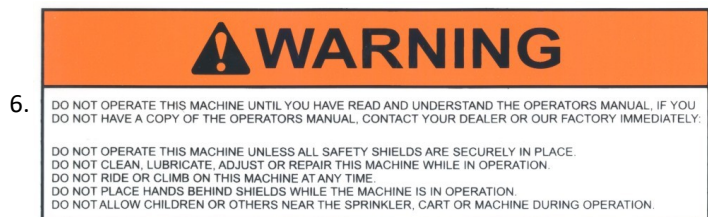
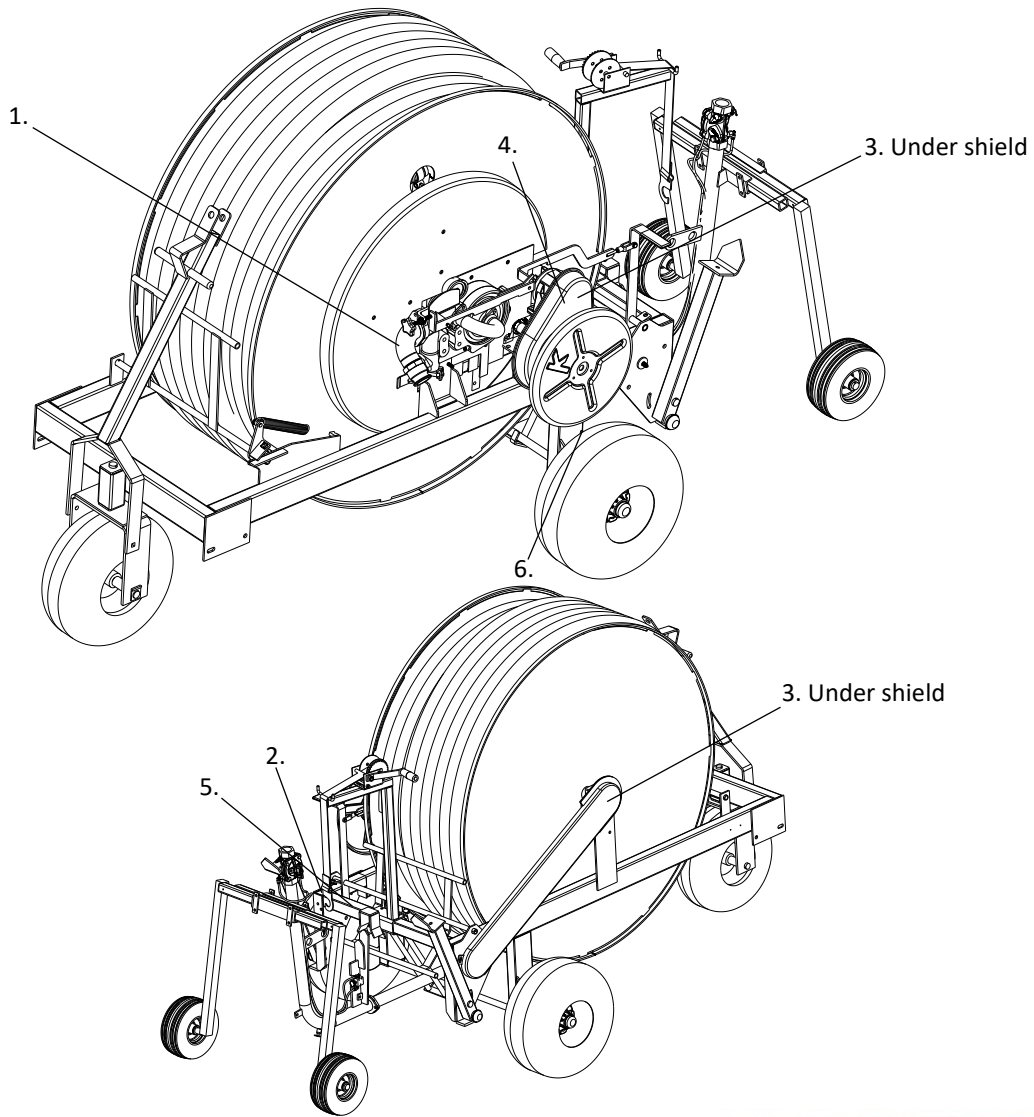

# Safety Precautions

## Learn To Be a Safe Operator

### Read This Manual

- Know the controls on the Water-Reel and how to stop the water supply.
- Do not allow anyone to operate this Water-Reel without proper instruction.

### General Precautions

- **Never attempt to service the Water-Reel while it is operating.**
- **Never attempt to make adjustments to the equipment while it is operating.**
- Perform recommended maintenance at suggested intervals.

### Protect Children

- Do NOT allow children to operate the Water-Reel.
- Keep children away while operating the Water-Reel.
- Do not allow children to operate the tractor that is positioning the Water-Reel.
- Never allow children to climb or ride on the machine at any time.

### Use Caution Around Pressurized Lines

- For your own protection, always take care when working with or around pressurized equipment. Shut off the unit and water supply before working with any components. This includes the supply lines, machine or any related equipment.
- Be sure the pressure is relieved from any supply line before it is disconnected.
- When the automatic sprinkler shut-off is used, pressurized water may be trapped in the system tube.
- Never service the equipment while it is pressurized or in operation.



### Stay Away from Operating Sprinklers

- Stay away and keep others away from the sprinkler head during operation. Pressurized water from a sprinkler can inflict serious injury to bystanders.

# Safety Precautions

## Learn To Be a Safe Operator

### Use Caution When Towing

- Your Water-Reel is not intended for highway towing.
- 10 MPH maximum on smooth surfaces.
- 3 MPH maximum on rough surfaces

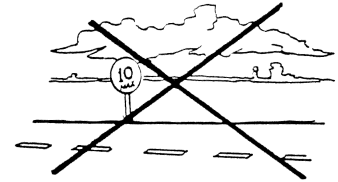

**NEVER TOW THE WATER-REEL IN EXCESS OF 10 MPH**

### Keep Hands and Clothing Away

- Do not reach into any part of the Water-Reel while it is in operation.
- All operators and spectators should keep a safe distance from all moving parts during operation.



### Keep All Guards and Shields in Place

- Never Operate this Machine with Safety Guards Removed!
- Should a shield or guard become damaged or lost, replace it prior to operation.



### Stay Away From Power Lines

- Avoid letting water contact power lines. Be careful not to contact power lines with irrigation pipe or mechanical equipment while operating or transporting you Water-Reel.



### Never Service or Make Adjustments While the Water-Reel is Pressurized

- Shut the water off at the source before attempting to do any service maintenance or adjustments

# Turbine Drive Controls

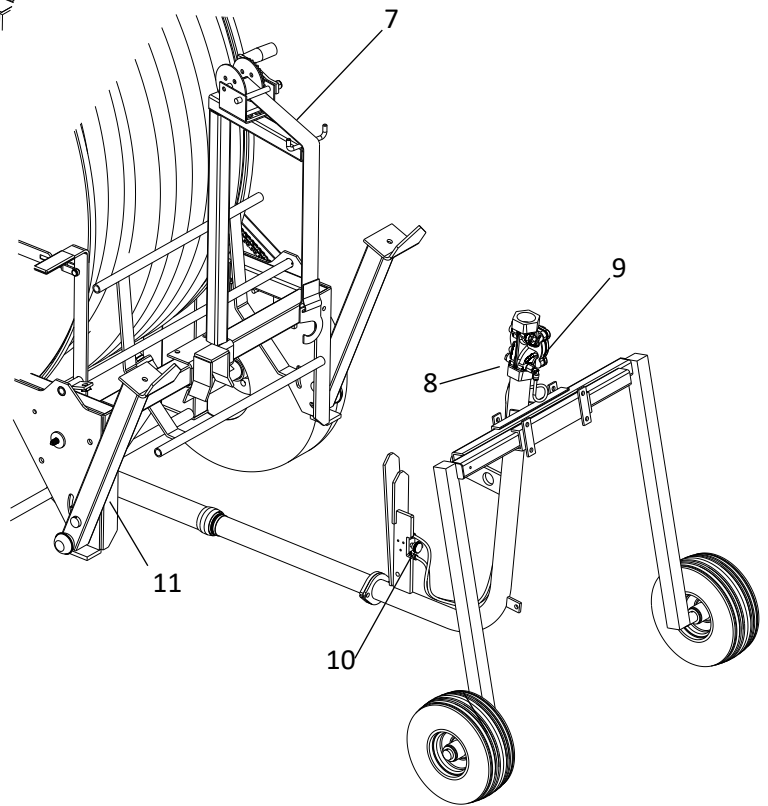
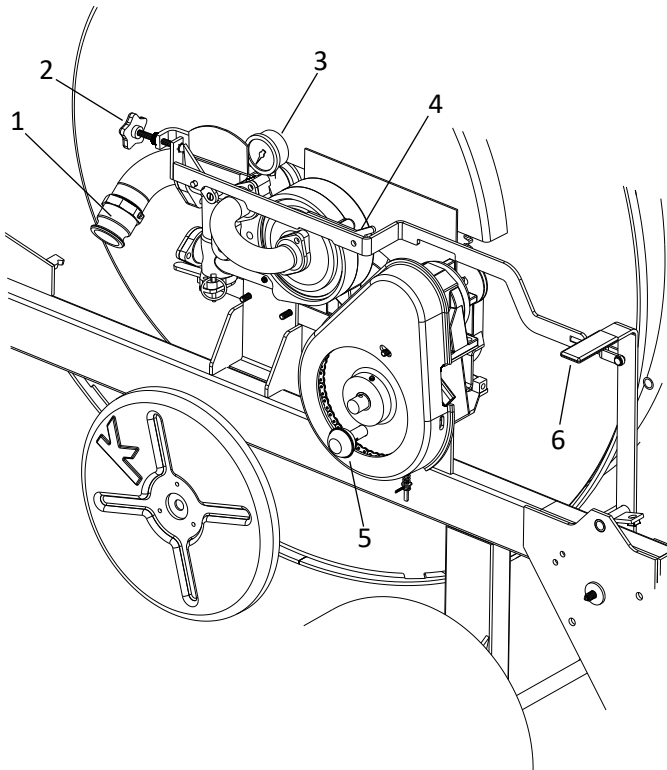

- 1. **Entry Fitting**—Supplies water to the machine
- 2. **Travel Speed**—Sets the Gun Cart retraction speed
- 3. **Pressure Gauge**—Shows water pressure (at the inlet)
- 4. **Shut-off Hold Out**—Locks the turbine to full by-pass (stop)
- 5. **Clutch Disengage Knob**—Disengages drive
- 6. **Shut-off Bar Handle**—Turns turbine off

- 7. **Transport Boom**—Carries the Gun Cart during transporting
- 8. **Pressure Relief Valve**—Relieves pressure in tube after run
- 9. **Sprinkler Control Selection**—Sets action of the sprinkler after irrigation run
- 10. **Actuator Valve**— Controls the Sprinkler to run or shut down after run
- 11. **Stabilizer Leg**— Secures machine for irrigation run

## Handling the Polyethylene Tube

The polyethylene irrigation tube is a durable product that will operate reliably for many years if handled properly and given a reasonable amount of care.

Medium Density Polyethylene is a semi-rigid product that retains its shape when it is not pressurized but can also be wound on a drum or spool without damage. This characteristic makes it feasible to pump fluid through it while it is rolled up on a reel.

A few simple precautions need to be observed to prevent damaging the tube when operating your Water-Reel.

1. **When starting a new Water-Reel for the first time, you must pull the tube all the way out in order to correctly tighten the new tube on the spool. It is also important to follow the timing Instructions on Pages 23-24 of this manual.**
2. **Never transport the Water-Reel with the Anti Return Pawl in the up position! The tubing will become loose and tangled.** Do not attempt to operate your Water-Reel if there are any coils of tube that are loose or misplaced. If loose coils of tube are noticed, they must be tightened by rotating the spool by hand. If this is not possible, pull all of the tube out before attempting to rewind the tube.
3. Never try to move or relocate the machine if the tube is not fully rewound onto the machine.
4. Never pull the tube off the machine other than by pulling on the sprinkler cart (straight out from the machine).
5. Never run over the tube with any kind of vehicle and avoid pinching or pulling the tube around objects. Never bend the tube sharper than 25 times the inner diameter of the tube (See page 14).
6. If the tube is frequently pulled out only a portion of its complete length the tube remaining on the drum will become loose. Occasionally it will be necessary to pull all the tube off the drum to tighten the remaining coils.

Be careful when operating other equipment near the tube. Make sure the tube doesn't get gouged or punctured.

**REMEMBER, polyethylene tube is semi-rigid and subject to being kinked. Those foregoing precautions will reduce the possibility of kinking or damaging your tube. Throughout the irrigation industry the words 'tube' and 'hose' are used interchangeably in connection with hard hose traveling machines.**

## Water-Reel Start-Up & Operation

The success of the Water-Reel irrigation system depends a great deal on the operator's understanding of the proper pull out and start up procedure. Do not attempt to operate this Water-Reel until you read and understand the preceding section titled "Handling the Polyethylene Tube"!

Decide on the proper nozzle size to be used for the irrigation run which thus will also determine the irrigation lane spacing that will be needed (see pages 21 for sprinkler performance).

Set the desired arc to be used on the sprinkler gun.

NOTE: Arc settings where the sprinkler never distributes water forward of the gun cart (towards pull), could create undesired tracking results. This is caused by the continuous thrust of the sprinkler, which pushes the tube towards the Water-Reel. It is recommended that the arc be set to create some tension on the tube greater than 180°).

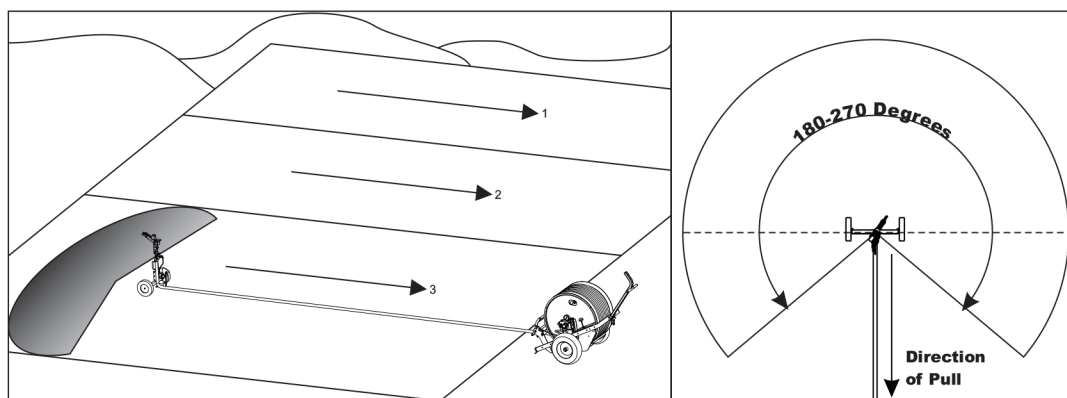

Note: Your Kifco Water-Reel is equipped to irrigate on a gradual arc if necessary. Arced irrigation can only be performed after the first 25% of the tube is pulled out straight from the machine and then the gradual arc cannot exceed 90 degrees over the remaining 75%. Depending on the soil or vegetation the gun cart may or may not follow the arc back to the machine. Higher friction (furrows, tall grass) will greatly assist with the gun cart tracking the arc.

Failure to observe this limitation can also place an excessive side load on the Level Wind mechanism which could result in equipment failure and/or tube damage.

# Water-Reel Start-Up & Operation

***Do not attempt to operate this Water-Reel until you read and understand the preceding section titled "Handling the Polyethylene Tube"!***

---

1. Pull the Water-Reel into position with the sprinkler cart towards the run to be irrigated. Be especially careful to have the machine square and in good alignment with the irrigation path. It is allowable for the tube not to be pulled out in a straight line, however, it is important that ***the first 25% of the tube be pulled straight away from the machine***. Failure to observe this limitation places excessive side load on the level wind mechanism and may result in equipment failure or tube damage.
2. Fold down the stabilizer legs and confirm they have made good ground contact. Make sure both legs swing freely at their hinges. ***Never*** attempt to operate the Water-Reel with only one leg down.

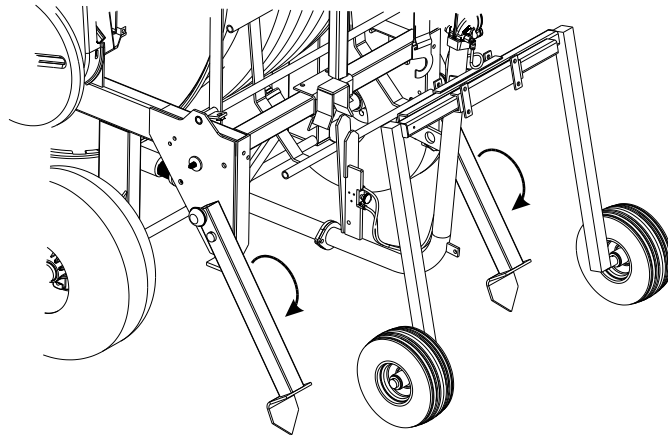

When the Water-Reel begins to operate with the tube pulled out, the machine may raise up onto the stabilizer legs. The machine is then resting on the front wheel and the stabilizer legs with the two main wheels off the ground. This is normal. Do not attempt to interfere with this action. The Water-Reel has been designed to maximize its capability to anchor itself. Also, front wheel must be straight. ***Do not turn the front wheel crossways.***

3. Disengage the clutch. To disengage, pull on dog knob and rotate 90° to locked out position.

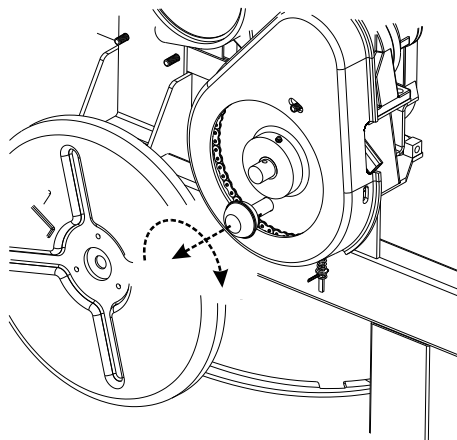

## Water-Reel Start-Up & Operation

4. Check spool brake for proper tension. There should be noticeable resistance to unrolling. The purpose of the spool brake is to prevent coasting of the spool during tube pull out. ***Coasting of the spool is the most frequent cause of malfunction!*** This problem is most common when the Water-Reel is frequently used in short runs and the entire tube is seldom pulled all the way out. When the spool coasts, it will appear that the Level Wind mechanism is out of time with the incoming tube, ***make no attempt to re-time the machine until it is determined that the tube is not loose.*** If the tube does become loose the only way to correct the problem is to pull the tube all the way out and allow the machine to operate a full-length run. See the "adjustments" section of this manual for adjusting the spool brake.
5. Attach the water supply line to the machine to confirm that all lines reach and the Water-Reel is set in the proper place. ***Do turn on the water.***

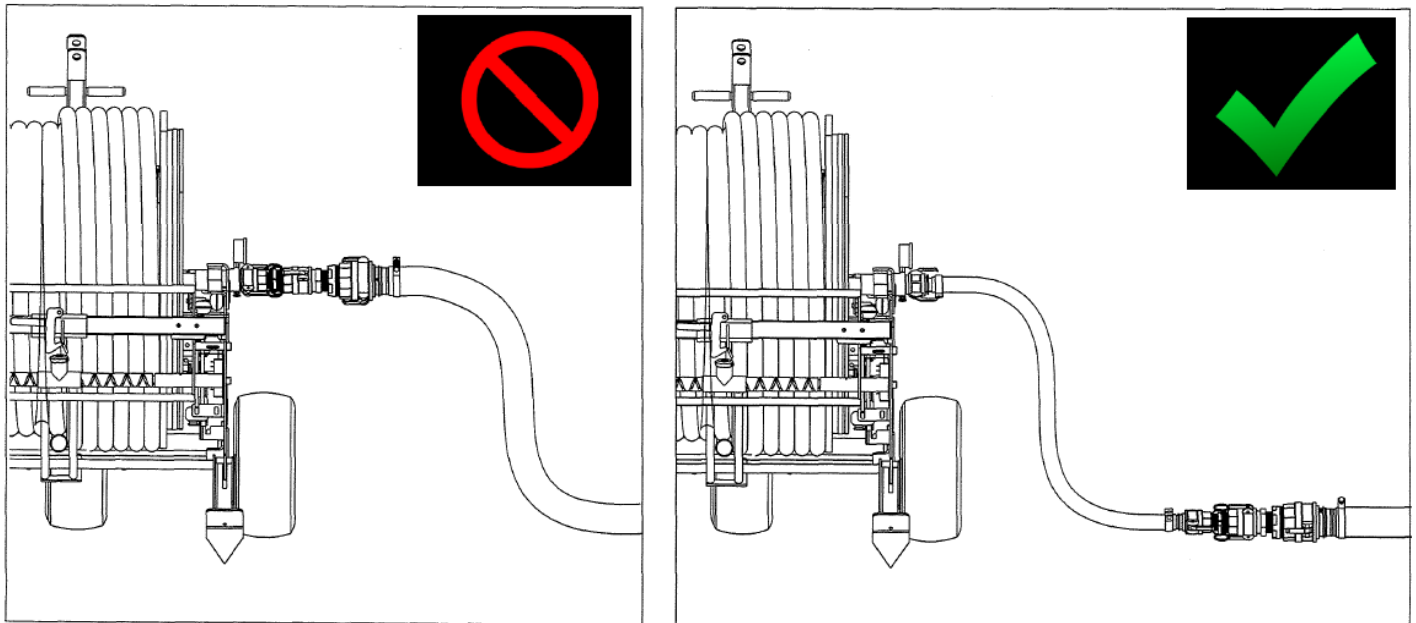

The inlet is designed to withstand the weight of Kifco's supply hose that was shipped with this machine. If additional reducers, fittings or supply hoses are needed, they need to be installed at the end of the standard supply hose included and NOT at the inlet of the machine. Incorrect installation of supply hoses will result in damage to the machine.

## Water-Reel Start-Up & Operation

6. Lower the sprinkler cart from its transport position. Determine if the automatic sprinkler shut off is to be used and set the desired sprinkler arc.
7. Connect to the Tow Chain on the Gun Cart. **SLOWLY** and **STEADILY** begin pulling **(3 MPH)** the Gun Cart and the Hose down the path to be irrigated. Avoid sudden stops or anything that will make the spool more likely to coast.

It is allowable for the tube not to be pulled out in a straight line, however, it is important that ***the first 25% of the tube be pulled straight away from the machine.*** Failure to observe this limitation places excessive side load on the level wind mechanism and may result in equipment failure or tube damage.

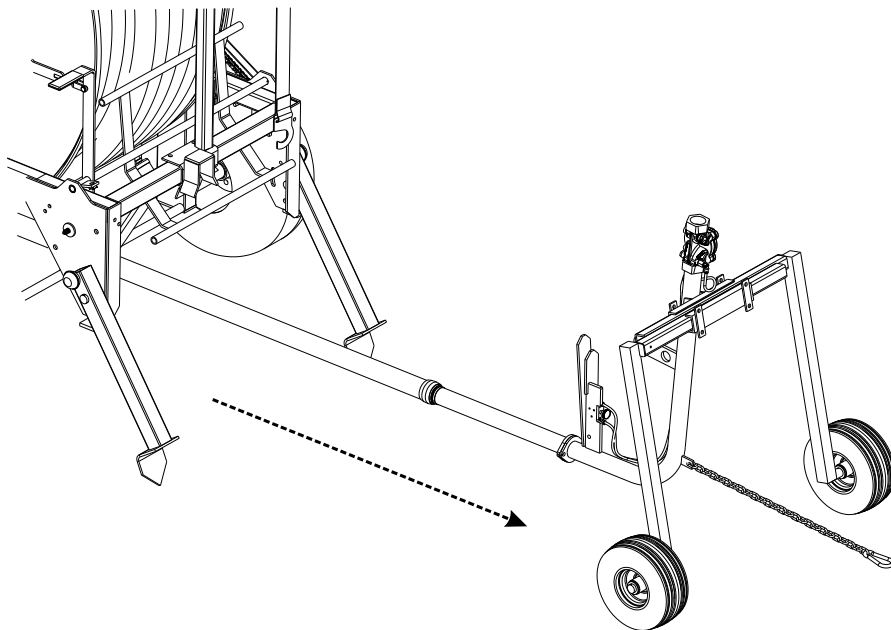

# Water-Reel Start-Up & Operation



## **Warning!**

**Stand clear of the Machine and the Gun Cart**  
**while the tube is being pulled out.**

**Note:** When the tube is pulled out to follow a contour or to avoid an obstacle, the extent that it is pulled in a curve should be very gradual. Under no circumstances should the tube curve more than 90 degrees in its entire length. How well the tube will follow its laid out path back to the machine will depend mostly on the surface of the ground. For example, if there are contours or furrows to follow, the tube may track back very well. If the soil or vegetation is slick and no rows or furrows exist, the tube may cut across the laid out path and be recoiled back on the machine in the shortest distance (a straight line).

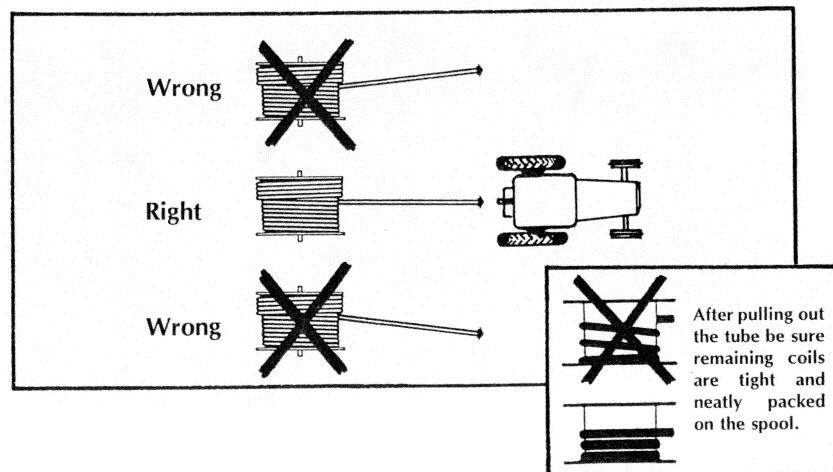

8. It is considerably easier to have an assistant back at the machine to warn the driver that the maximum length of hose has been reached.

If operating alone; the driver will be able to observe the white markings on the spool core beginning to show. This indicates to the driver that the maximum length of hose on the machine is about to be reached.

It is advised to leave one or two hose coil wraps on the spool when Gun Cart pull-out is complete. Tighten the remaining tube on the spool by rotating spool and packing coils together.

Disconnect the Tow Chain and store back onto the Gun Cart.

# Water-Reel Start-Up & Operation

9. Determine if the automatic water shut-off is to be used and set the valve accordingly. ***\*The Actuator Valve*** is a stem valve located on the Gun Cart of the Water Reel. This must not be used as an ON/OFF valve for any purpose other than to automatically shut-off the sprinkler at the completion of an irrigation run.

**Note:** Actuator valve **must** be reset before each irrigation run.

The Sprinkler Flow Selector Valve will only operate automatically if the Actuator Valve has been reset.

To ready Gun Cart for irrigation run: pull the Bumper back towards the hose. Press the Actuator Valve knob towards the valve body.

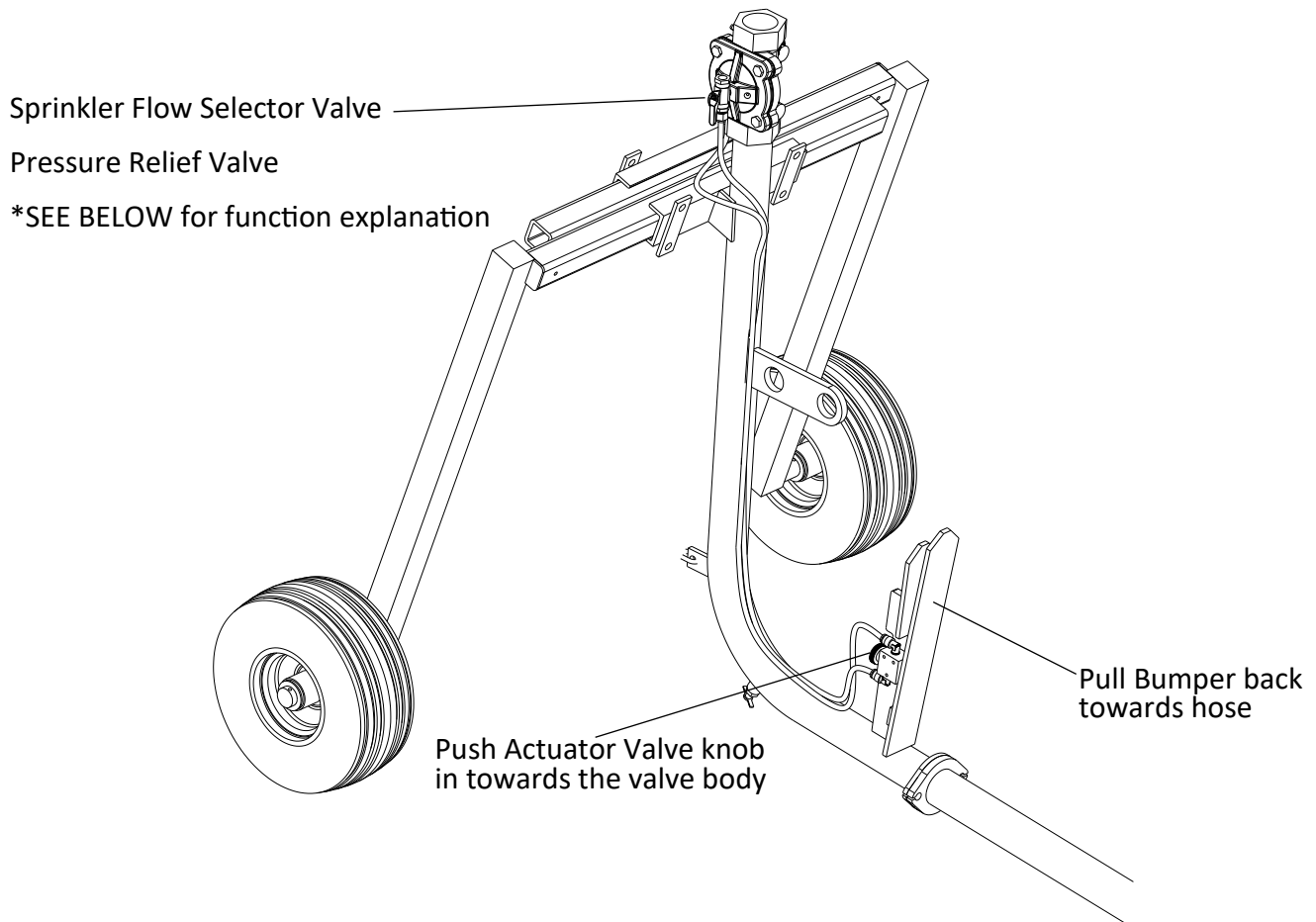

Sprinkler Flow Selector Valve **OFF**

**Sprinkler will NOT Shut off at end of run**

Sprinkler Flow Selector Valve **ON**

**Sprinkler will Shut off at end of run**

Most commonly used selection

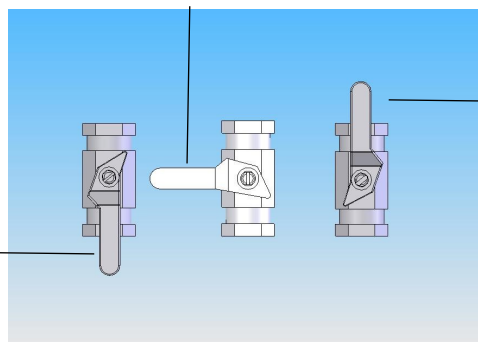

Sprinkler Flow Selector Valve **OFF**

**Sprinkler will NOT Shut off at end of run**

## Water-Reel Start-Up & Operation

10. Re-engage the Clutch Disengage Knob by turning it back 90° letting the split pin rest in the deeper groove of the clutch housing. **NOTE:** In some instances the Clutch Disengage Knob will not fully set back into the groove. This is due to the pin resting on the bar on the Clutch Dog located behind the sprocket. Once the turbine is engaged, the sprocket will begin turning and the Clutch Disengage Knob will drop into its full operating position.

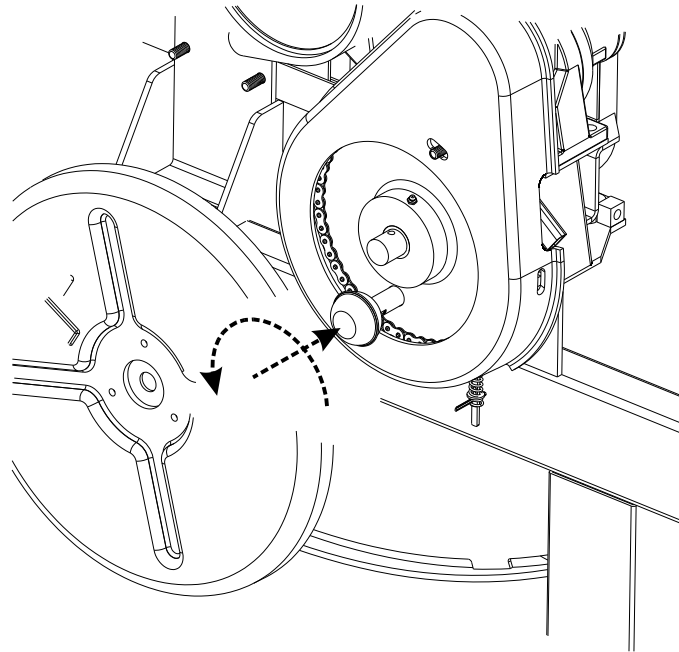

Pull and rotate Clutch Disengage Knob 90° to engage drive system

- 
11. Pull the handle on the Shut Off Bar slightly back then simultaneously push down on the Shut off Hold Out handle. Slowly release the Shut Off Bar handle to begin water flow through the turbine runner.

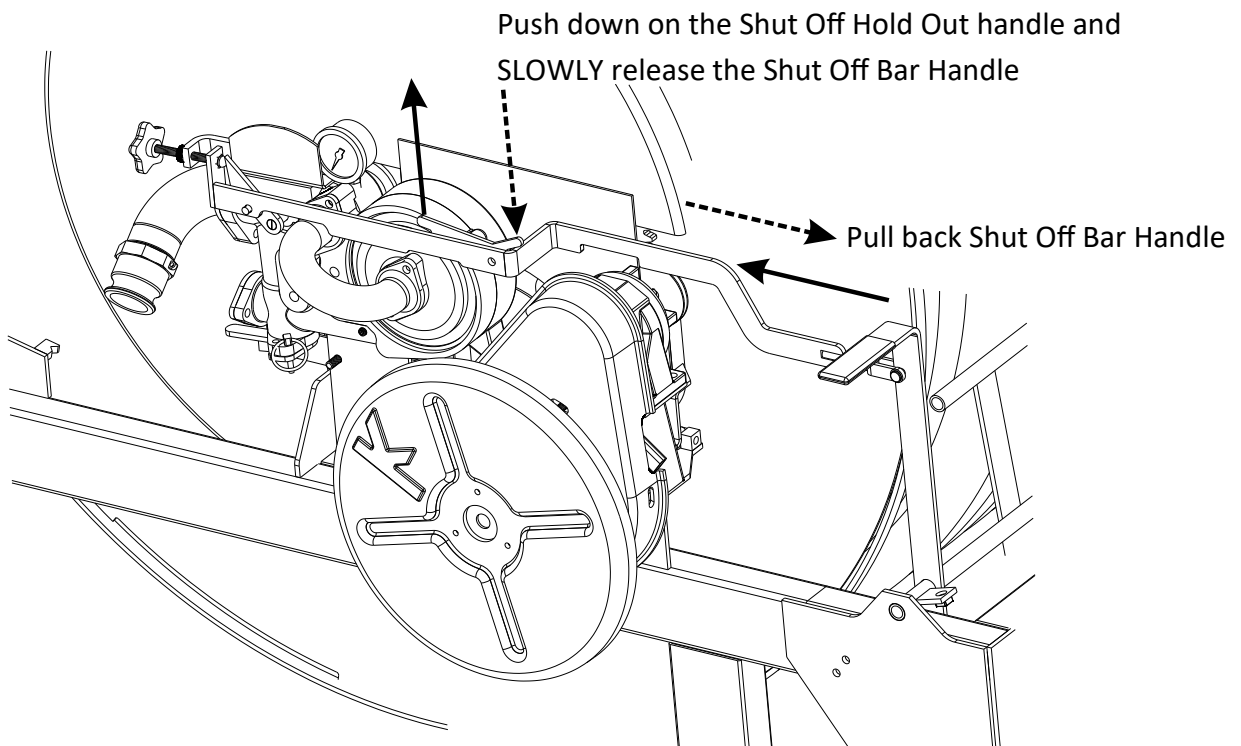

## Water-Reel Start-Up & Operation

12. Observe water pressure, travel speed, and sprinkler performance to confirm desired performance. See performance guide supplied with the machine.

### Turbine Drive Only

On initial start up, adjust lock nut (#3) on travel control screw. To adjust, turn speed control knob out until a noticeable pressure change has occurred (approximately 10 PSI). Once this is reached, screw lock nut to face of plate (nut is not used to lock screw, only to prevent over speed).

1. Speed Control Knob
2. Knurled nut, used to lock travel control screw.
3. Lock nut, used to prevent excessive pressure loss though turbine.

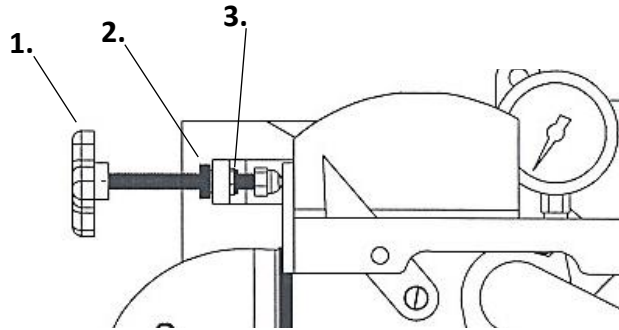

### Important

When using the automatic water shutoff feature, be sure the water can be shut off automatically without damaging the water supply or the Water-Reel! Stopping the flow of water can damage a pump or water lines and excessive pressure can be created. A qualified person should confirm if you could safely utilize the automatic water shut-off.

**Note:** Some municipalities prohibit the use of water mains intended for fire protection and there may also be requirements for back-flow prevention. Investigate and obey all local regulations regarding the use of water.

**Note: On completion of first run only!** Verify the Transport Boom is directly above the Bumper on the Sprinkler Cart Body. If it is not in alignment; loosen the mounting bolts and move the Transport Boom to its proper location.

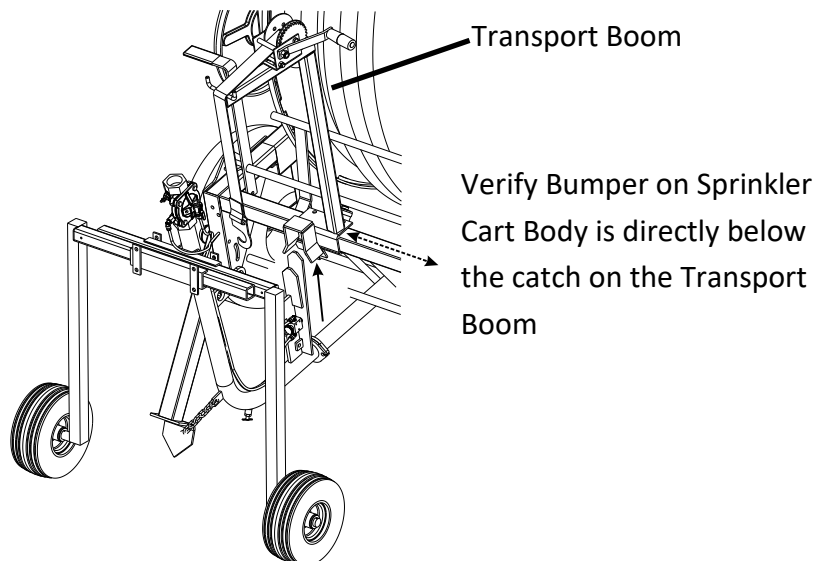

## Water-Reel Start-Up & Operation

13. With the irrigation run completed, turn off water supply.

**SLOWLY** turn the handle on the Sprinkler Flow Selector Valve upwards to relieve pressure in the machine.

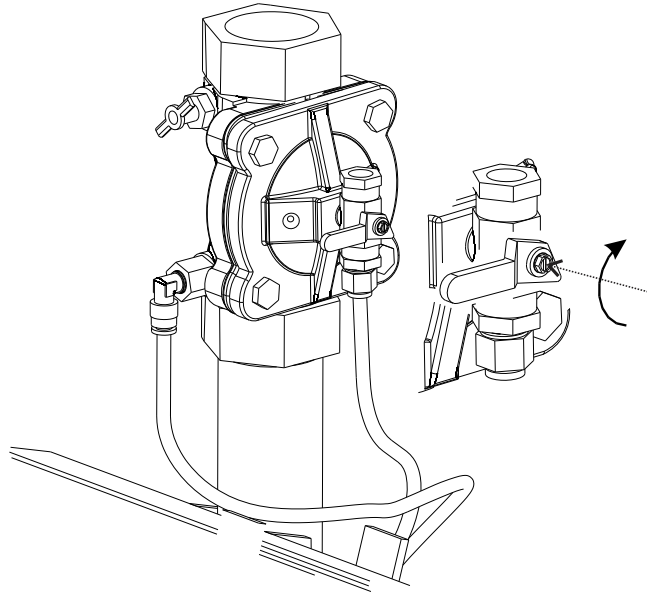

14. Raise and pin both Stabilizer Legs

Attach the hook on the Transport Boom to the Gun Cart. Fully raise the Gun Cart up into the hold on the Transport Boom.

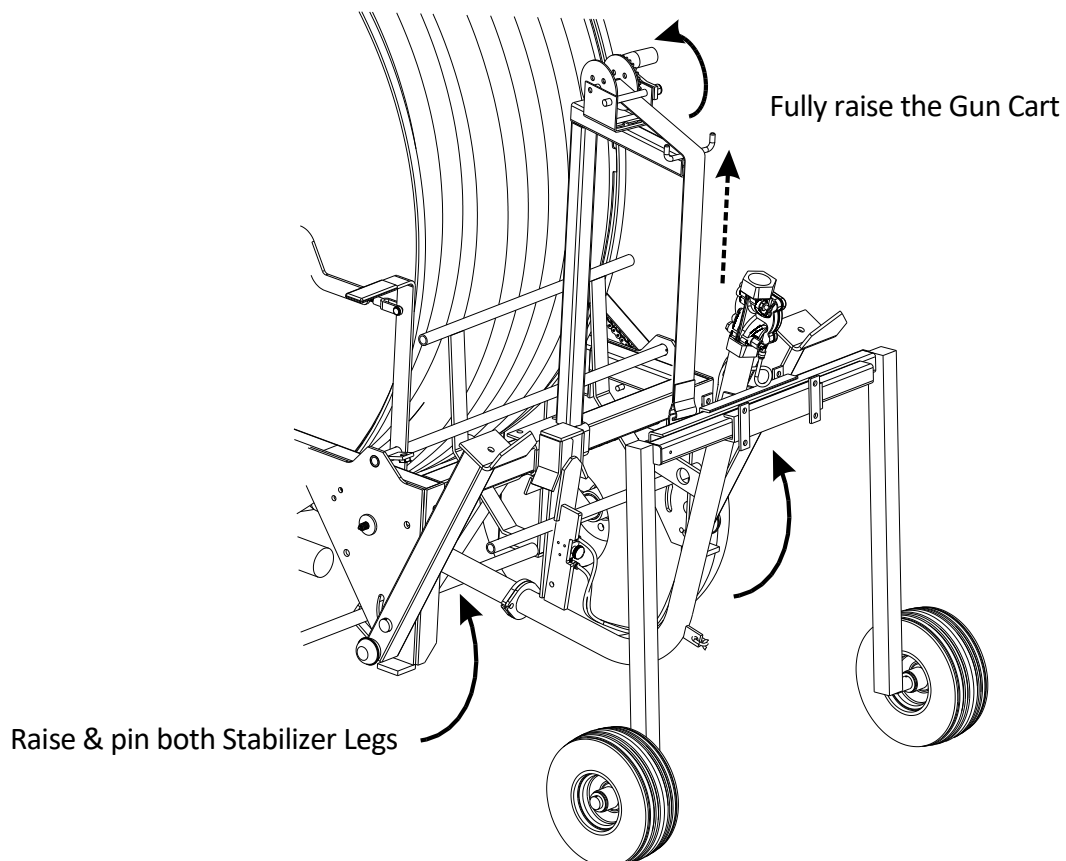

# Water-Reel Start-Up & Operation

## Anti-Reverse Pawl:

The Anti Reverse Pawl engages the teeth of the spool Drive Gear and prevents the tube from becoming loose on the spool due to spool backlash, at the end of the run or during machine transport. **NOTE: Clutch (Clutch Disengage Knob) must be engaged to prevent backlash.**

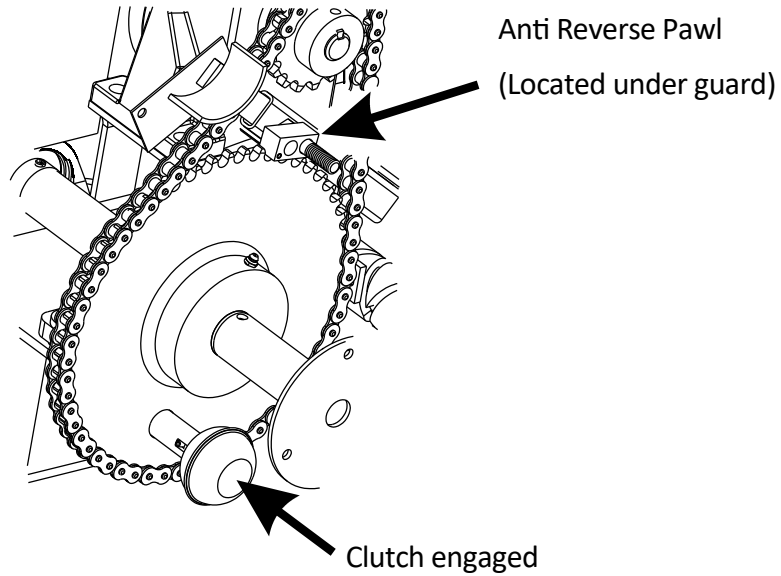

## Tube Rider:

The tube rider applies pressure to the tube preventing the tube from becoming loose as the sprinkler cart approaches the machine and sprinkler thrust tends to push the cart forward.

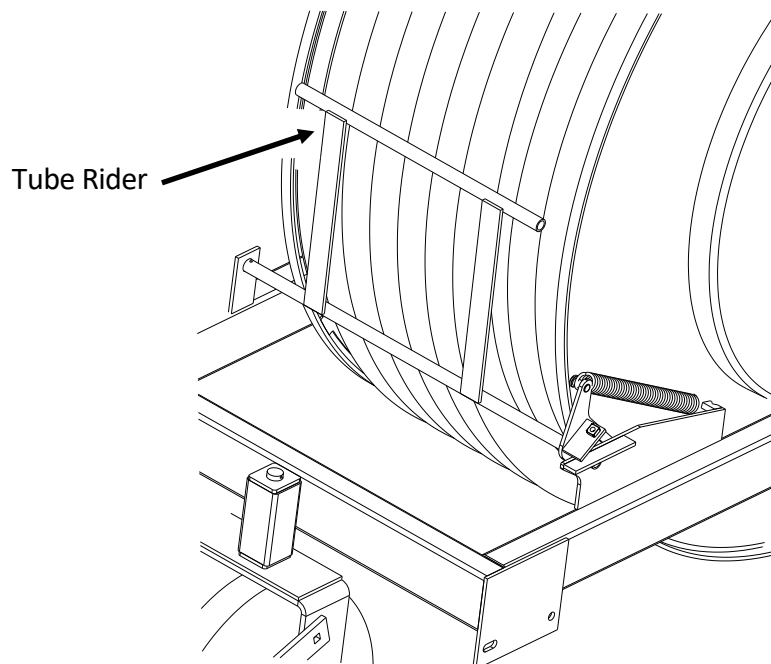

## Water-Reel Start-Up & Operation



**IMPORTANT:** If the standard irrigation run does not require the use of 100% of the tube on the Water-Reel; it will be necessary to occasionally pull the entire length of tube off of the Water-Reel and retract the tube under pressure to ensure the concentric shape of the tube. During short runs of the Water-Reel, the remaining tube on the spool will tend to gradually loosen. Over time, gaps in the tube on the spool will create Level Wind to tube mis-alignment causing the machine to become out of time or the possibility of the tube mis-wrapping causing damage to the Water-Reel and the tube. This can be corrected by making a full run (pull 100% of the tube out) occasionally.

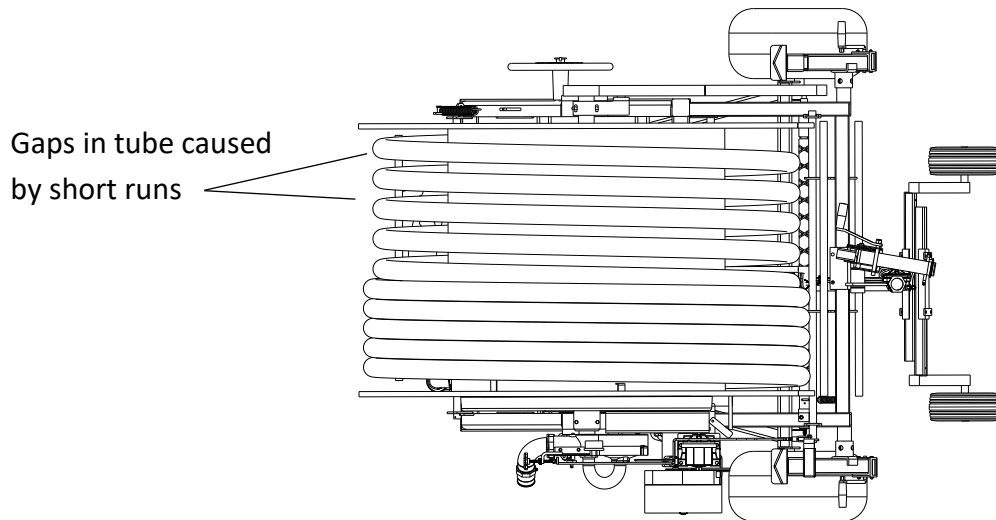

# Water Application Rate & Travel Speed

## Depth Of Water Applied:

The depth of water applied by the Water-Reel is regulated by the retraction speed (speed the sprinkler is moving over the ground). It is also affected by the amount of water being discharged by the sprinkler head. The sprinkler nozzle size and the water pressure determine the amount of discharged water. These two factors are determined by the available water and the capability of the water pump at the water supply. The selection of the sprinkler nozzle needs to be made based on the water supply and pump performance.

## Travel Speed Settings - Using the Performance Guide:

Example: With a Nelson SR75 sprinkler, determine the inlet pressure, speed settings and sprinkler nozzle size required to apply 0.80 - 1.00 inches of water. (See Illustration)

Note: The inlet PSI is the pressure reading while the machine is running and the sprinkler is operating. If the pressure drops while running, use the chart to determine the performance at the new inlet pressure. If the pressure drops below the lowest inlet pressure shown, consider using a smaller size nozzle. (Inlet PSI is always read at the Water Reel )

As shown below, a variety of settings can accomplish 0.80 - 1.00 inches of water application.

\*With a .4" nozzle and an inlet PSI of 55; 0.80" can be applied at a rate of 24 ft. per hour.

\*With a .65" nozzle and an inlet PSI of 73; 1.00" can be applied at a rate of 38 ft. per hour. Example shown below

\* With a .75" nozzle and an inlet PSI of 93; 0.80" can be applied at a rate of 61 ft. per hour.

Variances with inlet pressures and nozzle sizes will give different application speed rates and irrigated areas.

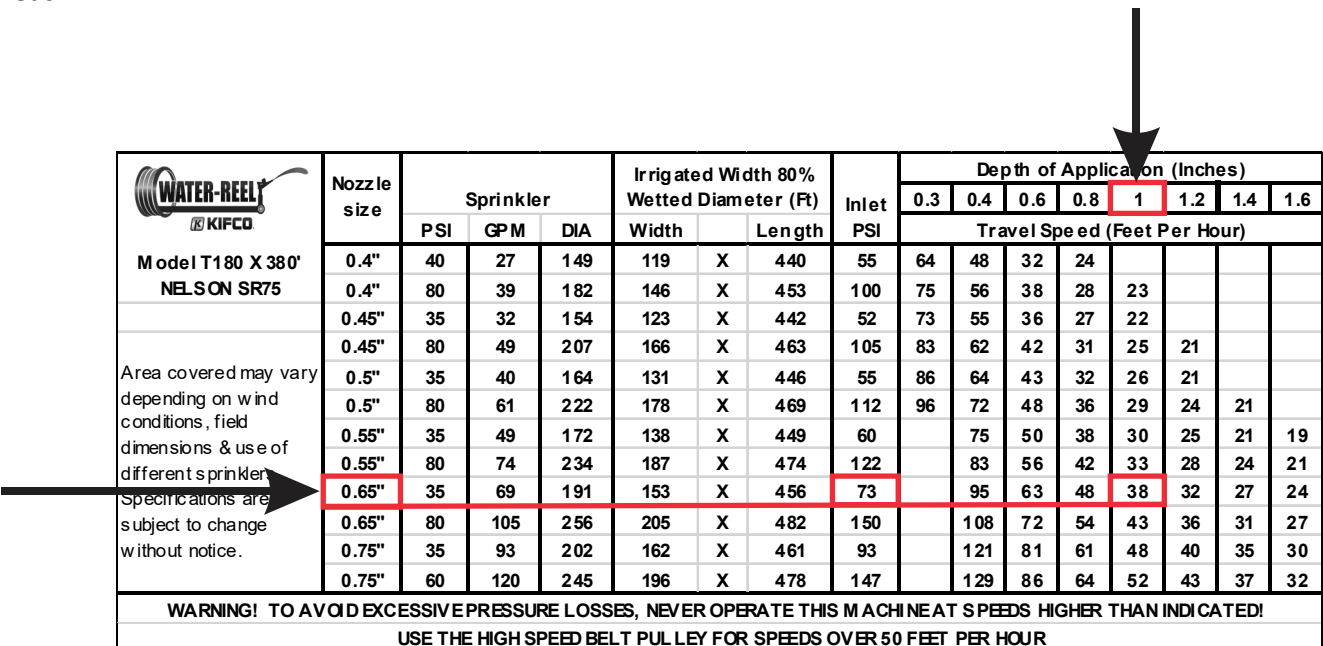

 Model T180 X 380' NELSON SR75	Nozzle size	Sprinkler			Irrigated Width 80% Wetted Diameter (Ft)		Inlet PSI	Depth of Application (Inches)										
		PSI	GPM	DIA	Width	Length		Travel Speed (Feet Per Hour)										
								0.3	0.4	0.6	0.8	1	1.2	1.4	1.6			
Area covered may vary depending on wind conditions, field dimensions & use of different sprinkler Specifications are subject to change without notice.	0.4"	40	27	149	119	X	440	55	64	48	32	24						
	0.4"	80	39	182	146	X	453	100	75	56	38	28	23					
	0.45"	35	32	154	123	X	442	52	73	55	36	27	22					
	0.45"	80	49	207	166	X	463	105	83	62	42	31	25	21				
	0.5"	35	40	164	131	X	446	55	86	64	43	32	26	21				
	0.5"	80	61	222	178	X	469	112	96	72	48	36	29	24	21			
	0.55"	35	49	172	138	X	449	60		75	50	38	30	25	21	19		
	0.55"	80	74	234	187	X	474	122		83	56	42	33	28	24	21		
	0.65"	35	69	191	153	X	456	73		95	63	48	38	32	27	24		
	0.65"	80	105	256	205	X	482	150		108	72	54	43	36	31	27		
0.75"	35	93	202	162	X	461	93		121	81	61	48	40	35	30			
0.75"	60	120	245	196	X	478	147		129	86	64	52	43	37	32			

**WARNING! TO AVOID EXCESSIVE PRESSURE LOSSES, NEVER OPERATE THIS MACHINE AT SPEEDS HIGHER THAN INDICATED!**  
**USE THE HIGH SPEED BELT PULLEY FOR SPEEDS OVER 50 FEET PER HOUR**

# Adjustments

## Level Wind Timing:

Proper timing of the Level Wind mechanism is essential to the successful operation of the Water-Reel. Improper Level Wind timing will result in mis-wrapped tube. Travel will be interrupted because the auto shutoff bar will stop the water motor in order to prevent damage to the irrigation tube. **Do not continue to operate if the tube is not winding properly!**



**Important!** Be positive that the timing is really at fault before attempting to change the timing. Your Water-Reel was shipped from the factory with the tubing wound on it. The Level Wind timing was set at the factory prior to installing the tube. If there has been no disassembly of the Level Wind mechanism, or the tubing removed & reinstalled, it is very unlikely that the timing is wrong. If the tube is loose on the spool the Level Wind system will appear to be out of time. ***(See item #4 in the Water-Reel Start-up & operation section of this manual and also the brake adjustment section).***

To re-time the Level Wind, these steps **must** be followed:

1. Pull all the irrigation tube out from the Water-Reel. The elbow to which the tube is fastened must be on 45° with the elbow outlet pointed toward the sprinkler cart. (See Figure 1). Be especially careful not to pull the tube off the elbow. You may wish to stop slightly before the elbow is exactly on 45° location and turn the spool the last few degrees by hand.
2. Observe the position of the tube follower on the horizontal Level Wind screw. The tube follower must be in its most extreme position (all the way to the end of the Level Wind screw thread) and on the same side of the Water-Reel as the spool elbow. (See Figure 2). Align the timing mark with the timing mark decal arrow.

Figure 1

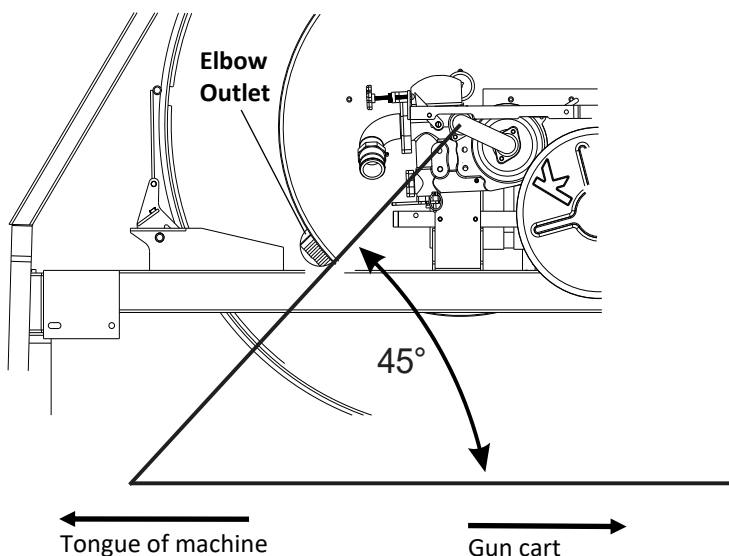
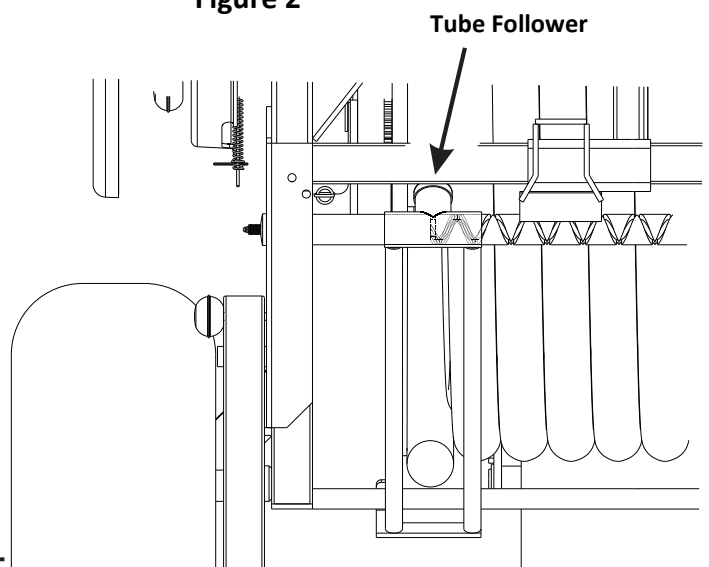

Figure 2



# Adjustments

- To change the timing, remove the shield and Level Wind drive chain from the right hand side of the Water-Reel. Rotate the Level Wind input sprocket until the tube follower is positioned as described in step #2. Reinstall the Level Wind drive chain and shield.

The Level Wind will now be in proper timing

Rotate sprocket until the follower is at its furthest point and the decal lines up with the mark on the Level Wind screw

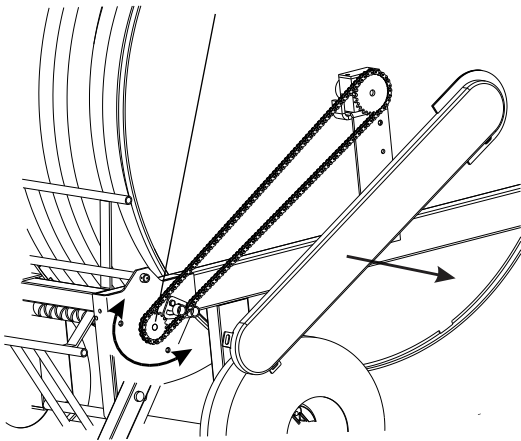

Timing Mark on Level Wind screw

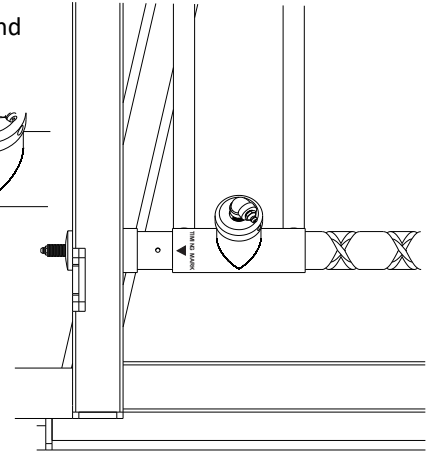

## Important

Never attempt to retime the Water-Reel without first pulling all the tube out. Changing the timing with some of the tube still on the spool may result in damage to the irrigation tube and/or the Water-Reel.

## Sprinkler Options and Adjustment

1) Nozzle

2) Part Circle Pin

3) Part Circle Stops

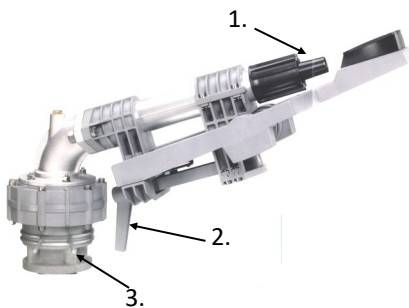

### Komet Twin Max

Part circle stops can be to provide any desired arc of operation. No tools are required to change the arc. **Do not** attempt to remove the spring clips from the base of the sprinkler.

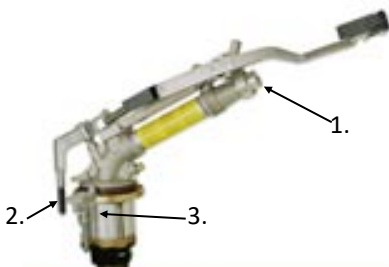

### Nelson SR-75

Part circle stops can be rotated to provide any desired arc of operation. To adjust the stop slacken the lever bolt, move the stop and re-tighten

# Adjustments

## Adjusting Spool Brake

The purpose of the spool brake is to prevent coasting of the spool when the tube is being pulled out. This function is important in order to keep the tube from becoming loose on the spool.

The brake band must be in good working order and maintained at the proper tension. The brake should offer substantial resistance to turning the spool by hand

To adjust the spool brake, remove the cotter pin under the spring. Using Pliers, pull up on the spring and reinsert the cotter pin in a hole above the previous selection.

**Note:** When the tube becomes loose on the spool, it may appear that the Level Wind is not in time with the incoming tube. This occurs because the spool is coasting inside the coils of tube. The Level Wind mechanism is moving but no tube is coming out.

This problem is more noticeable if the Water-Reel is being used on short runs where the entire tube is seldom pulled all the way out.

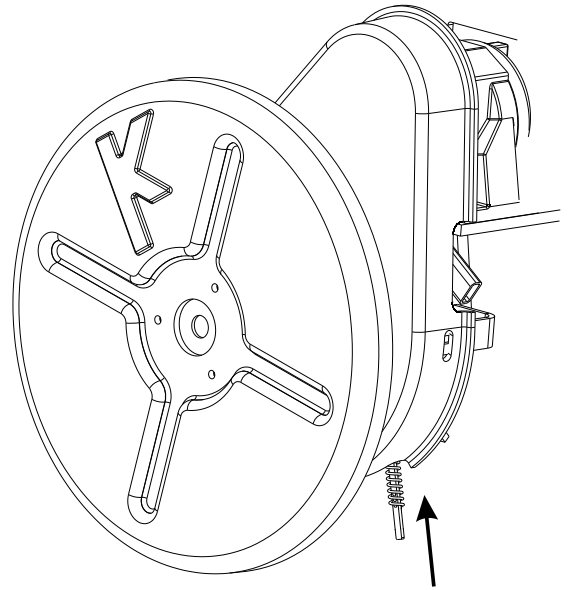

---

## Turbine Speed Adjustment

The turbine speed is controlled by the position of the butterfly valve. As the butterfly opens, water can pass the turbine. The speed can be adjusted by turning the travel speed con-

**Speed: Fast**

**Butterfly CLOSED**

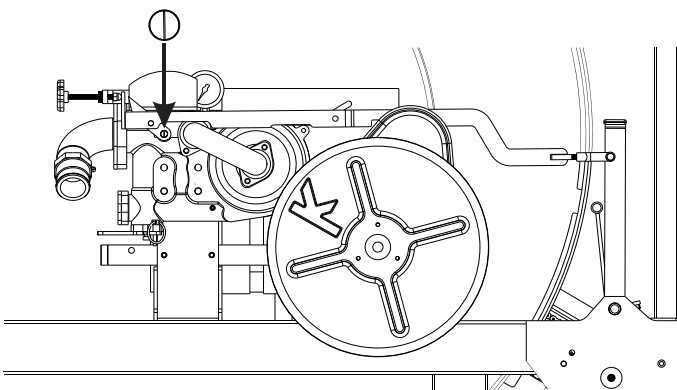

**Speed: Stopped**

**Butterfly OPEN**

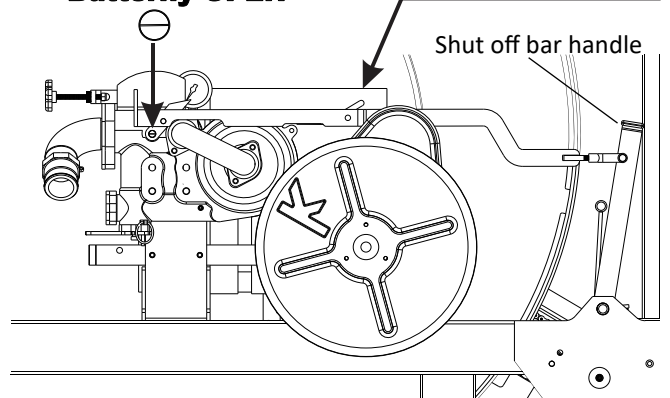

To adjust turbine speed, refer to the [Water-Reel Start-Up & Operation](#) section on [page 17](#) (Turbine Only)

To manually stop tube rewind pull handle on shut off bar back so the shut off latch drops into position.

**Note:** Latch will lock the bar in the OFF position; latch must be released to restart the turbine.

# Adjustments

## ***Tube Rider Bar Adjustment***

Adjust the tube rider bar ( using the adjustment bolt on the right side of machine ) so the distance between the bar and the spool core is 5 inches then tighten locknut.

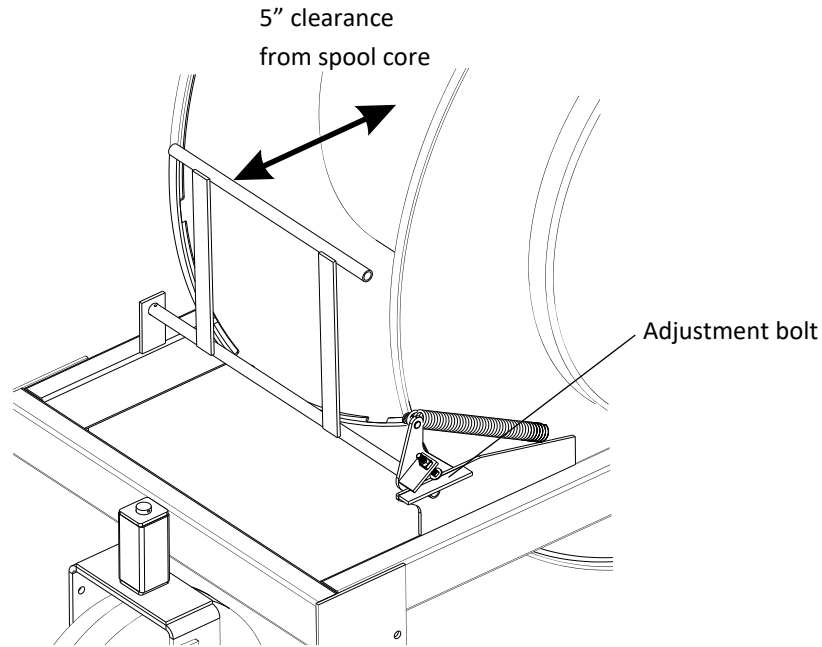

---

## ***Engine Drive Only***

Travel (rewind) speed adjustment

The travel speed of an engine drive machine is determined by the engine R.P.M. which is adjusted by the engine throttle.

On units with standard slow speed drive train configuration 3600 engine R.P.M. produces a \*average re-wind top speed of approximately 15 inches per minute.(75 f.p.h.)

Adjust engine speed to achieve desired rewind speed, Minimum engine recommended speed of 1800 R.P.M. produces average rewind speed of approximately 7 inches per minute.(37.5 f.p.h.)

On units with standard high speed drive train configuration, 3600 engine R.P.M. produces an \*average re-wind top speed of approximately 120 inches per minute, with the average low rewind speed being 60 inches per minute.

\* NOTE- Average rewind speed is the rate of tube re-wind at mid point of the run when the spool is approximately half full.

Speeds other than standard can be achieved, consult factory for recommendation.

Recommended engine speed for sustained operation is 1800 to 3600 R.P.M.

# Polyethylene Tube Repair

Tube menders can be purchase from your Kifco Dealer



**Warning!** Installing fittings or repairing polyethylene tube used on your Water-Reel is hazardous! The tube has a memory from being coiled on a reel and will try to coil back up if the tube is loosened from one end or cut in two. The condition possesses a serious hazard to person and/or property. The tube must be restrained any time there is a loose end!

## Polyethylene Tube Repair

Screw-in menders are an excellent alternative to butt-fusion welding for the repair of polyethylene tube. The compact design allows a mender to be wound onto the spool without damaging itself or the adjacent coils of tube. They can be installed in the field and the tube can be put into service immediately after the repair is made. The menders are designed to be fitted at ambient temperature. Never try to apply heat to assist installation. Menders must be installed straight and concentric with the tube to prevent premature failure.

### Installation Instructions

#### Step 1:



Cut the tube on either side of the damaged area. Make good, straight cuts. Use a block of wood or soft hammer to tap the collar fully on to the end of the tube.

#### Step 2:



Chamfer the tube internally with a knife or coarse file so that the end of the screw-in mender will enter the tube.

#### Step 3:

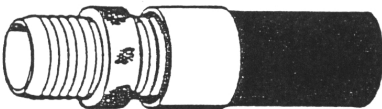

**Important:** Please note the mender threads are different on each end. One is left hand and one is right hand. Screw the mender about 2/3rds into the end of the tube using a wrench on the center knurled shoulder. Then unscrew it. Repeat the procedure for the other end. Watch for the left hand thread.

#### Step 4:



Now start the mender in both ends simultaneously. As it screws in, it will draw both ends of the tube to the center. This time, screw it all the way to the shoulder. The tube should now be ready to go immediately back into service.

# Repair & Maintenance

## Filter

Your Water-Reel is equipped with a filter to protect the water motor from dirt and debris, which may be present in the irrigation water. The filter protects **only** the water motor. The water flowing out of the sprinkler is not filtered.

To clean the filter; turn OFF water supply, remove the Filter Drain on the bottom of the turbine manifold, and pull out filter with fingertip. Clean and inspect the filter than reinstall.

**Never** attempt to remove the filter while the machine is pressurized. Always turn off the water supply and relieve pressure before starting any form of maintenance.

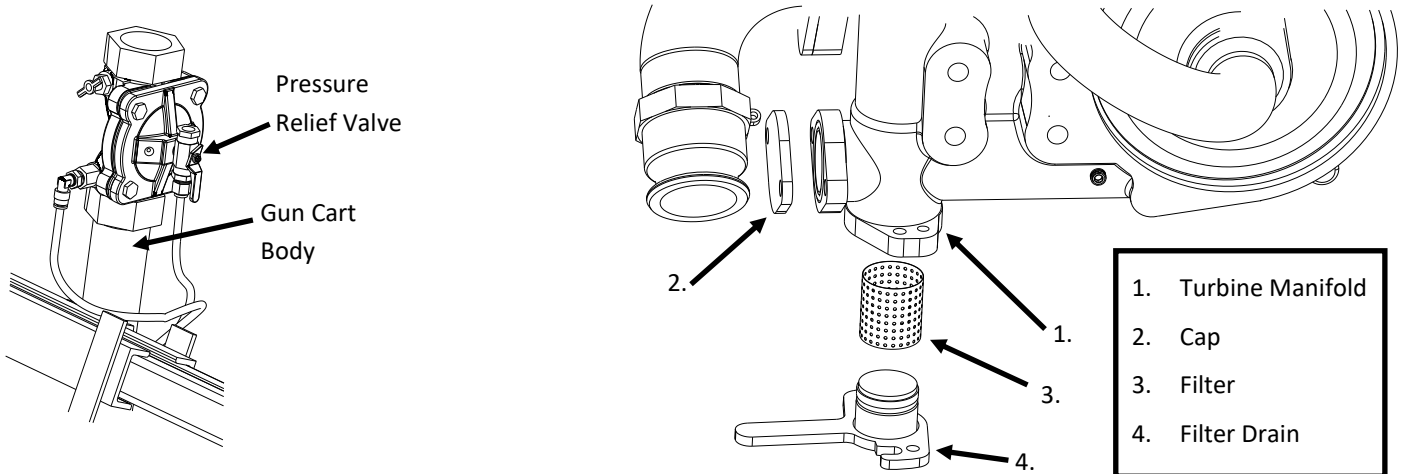

The filter should be cleaned at least once each season, even when operating with clean water. When pumping from ponds or streams, the filter must be cleaned more frequently. In very dirty water conditions, it may be necessary to clean the filter each time the Water-Reel is used.

## Valve Plumbing

The Actuator Valve signals the sprinkler control valve by supplying pressurized water to the diaphragm of the water sprinkler control valve at the completion of the irrigation run.

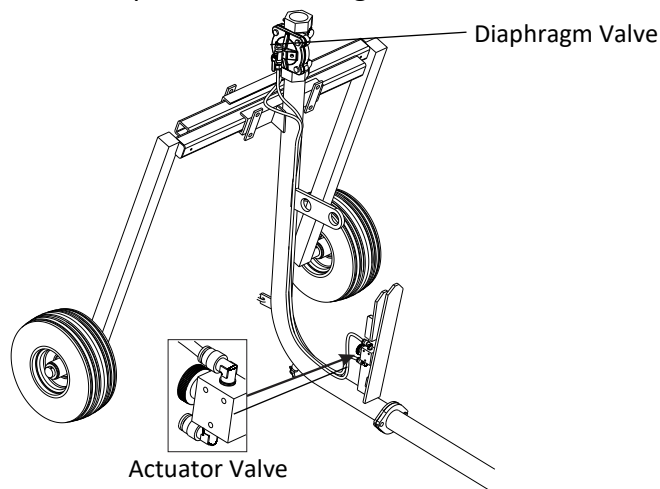

**Note:** In applications where the water has a high mineral content, buildup of minerals in the actuator valve can cause the valve to be difficult to shift.

To free the valve, apply liquid detergent to the exposed ends of the valve stem, or in the top fitting (after removing tube) and work the stem back and forth by hand.

# Repair & Maintenance

## Detaching Tubing From Fittings

1. Push the collar on the fitting completely in.
2. Firmly pull the Synflex tubing straight away from the fitting.

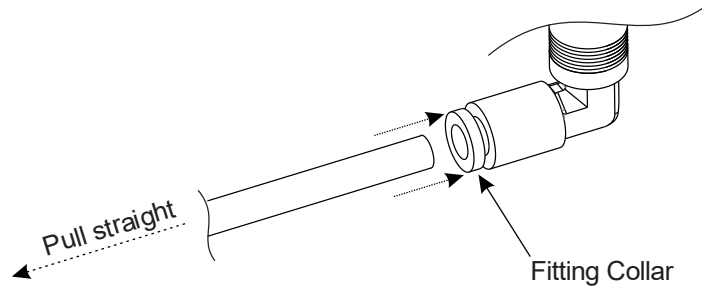

---

## Winterizing and Storage

For winter and/or off 'season' storage do the following:

### **Winterizing**

1. Open the drain plug on the gun cart and remove the filter cap on the base of the turbine manifold.
2. Be certain the water inlet to the Water-Reel is open and the water supply hose removed. Pull 3 or 4 coils of tube off the hose spool. Rewind the coils of tube by hand. *Freezing will not damage the type of Polyethylene tube used on your Water-Reel.* Even though the tube does not need to be drained you must take care to drain all metal parts.
3. Remove plug, and open petcocks to drain gun cart body and sprinkler control valve.
4. If the machine is equipped with a booster pump, the pump must also be drained.

### **Storage**

1. Lubricate all points in the lubrication chart to prevent rust and corrosion from forming.
2. Check and Clean filter.
3. Store the Water-Reel away from the direct rays of the sun.
4. Make sure all openings such as the water inlet are plugged so rodents and insects cannot bring foreign material into the Water-Reel.
5. When taking the Water-Reel out of storage, be sure there are no rodent or insect nests that may plug filters, valves or sprinkler.
6. If a Booster Pump is installed it is recommended to service the engine in preparation for the next season.

## **Booster Pump Operating Instructions**

The Booster Pumps fitted to Kifco Water-Reels are for the sole purpose of adding pressure to an incoming water supply. These pumps should **NEVER** be allowed to run dry. The pump seals will be damaged if the pump body is not full of water when the pump is running.



The Booster Pump engine is supplied with fuel from an auxiliary fuel tank mounted beside the engine. **Never refuel while the engine is running.**

### **Starting The Engine/Pump**

Before attempting to start the engine check fuel and oil levels. The oil level is very important. Also check that the water flow control valve at the sprinkler cart is in the on position. **Water must be running through the pump.**

### **Start-up Procedure**

1. Turn the ignition switch to 'On'
2. The fuel line valve below the tank and valve on the engine must be 'On'
3. If the existing water supply produces water flow that is too low the **Flow Switch** will prevent the engine from starting on units so equipped. To by-pass the Flow Switch depress the button mounted on the engine cover beside the gauge and hold down until the engine has started and the flow is sufficient for the engine to run with the by pass button released.
4. With the booster pump running a pressure increase should be observed on the machine pressure gauge. Use the engine throttle to control the water pressure. If there is no apparent increase in the water pressure, stop the engine and check the water supply.

**Note:** A pump inlet pressure gauge is installed to read the incoming line pressure. If this gauge shows little or no line pressure it is an indication that there is something wrong with the water supply. e.g. The supply line is too small or there is a restriction in the line.

**Important - Please be sure to read and understand the following note.**

### **Engine Choke**

The choke lever on the booster pump engine may have a mid-position that can be used for engine warm-up. **It is imperative that the choke lever is in the full open position when the engine is in normal operation.**

The booster pump operation is such that the engine must accept full load as soon as it starts, therefore the engine may require a partial choke setting for a few seconds after starting. If the choke is left partially on, it will damage the engine. The oil will become contaminated with gasoline and/or a heavy carbon buildup will form inside the engine, which will make the engine seize.

# Booster Pump Operating Instructions

## **Automatic Shutdown**

At the completion of an irrigation run the engine will shutdown automatically if the sprinkler control selector valve on the Gun Cart has been set to shut off the water supply. (See Page 15) Otherwise the engine will run until it is manually stopped.

### **Important Safety Message**



If the automatic shutdown feature is in use or the nozzle becomes plugged and the pressure switch fails to stop the engine, the water inside the pump will become scalding hot. The booster pump is equipped with a high temperature valve, which discharges a small quantity of water to prevent the water in the pump from becoming too hot. The valve is located on the pump volute as indicated in the drawing below. It can also be installed in place of the drain plug. Do not operate this pump if this valve is not in place or is damaged. **Do not attempt to plug the discharge port of the high temperature valve!**

**Maintenance (Note.** New engines are shipped **without** oil!!!) Use Type SAE30 Oil

Regularly check the engine oil level. Make periodic oil and air cleaner changes. Read the engine manufacturer's manual for instructions and maintenance procedures.

## **Oil Alert - Please note the following:**

The Honda engines used on the booster pumps are equipped with a low oil level switch. If the engine becomes low on oil, it will stop. To avoid unwanted shutdown of the pump, it is important that the engine oil level be kept full.

**Note:** The dipsticks on the Honda engines are designed to indicate the proper oil level when the checking plug is unscrewed. Remove the dipstick, wipe it clean and check the oil level without screwing it back into the engine. Be sure to follow the engine manufacturers recommendations when checking the oil level. Just removing the plug and checking the level may give a false reading that is higher than actual oil level.

## **Winterizing**

The pump must be drained of water. To drain the pump, remove the plug from the bottom of the pump body. Service the engine in preparation for the next season.

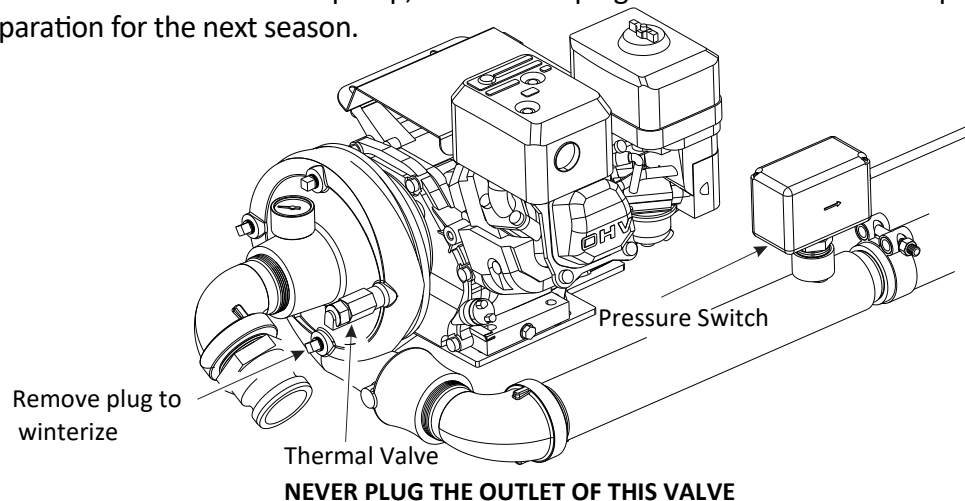

# Specifications

Model	WRT-4	WRT-4
PE Tube ID (inches)	1.8	2.0
PE Tube Length (Feet)	380	320
Dry Weight (lbs)	890	900
Weight w/Water (lbs)	1260	1340
<b>Machine Dimensions (Ft-in)</b>		
Length - A	5-4	5-4
Length w/Cart - B	6-0	6-0
Width - C	4-3	4-3
Height - D	4-9	4-9

WRT-5	WRT-5
2.0	2.1
580	320
1290	1220
2000	1820
<b>Machine Dimensions (Ft-in)</b>	
7-6	7-6
10-6	10-6
5-0	5-0
5-8	5-8

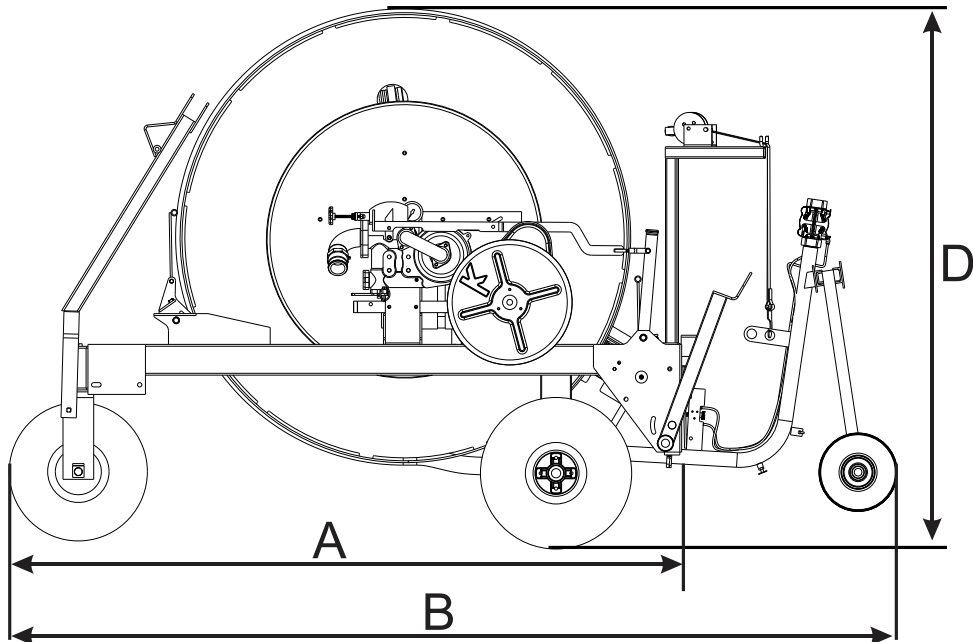
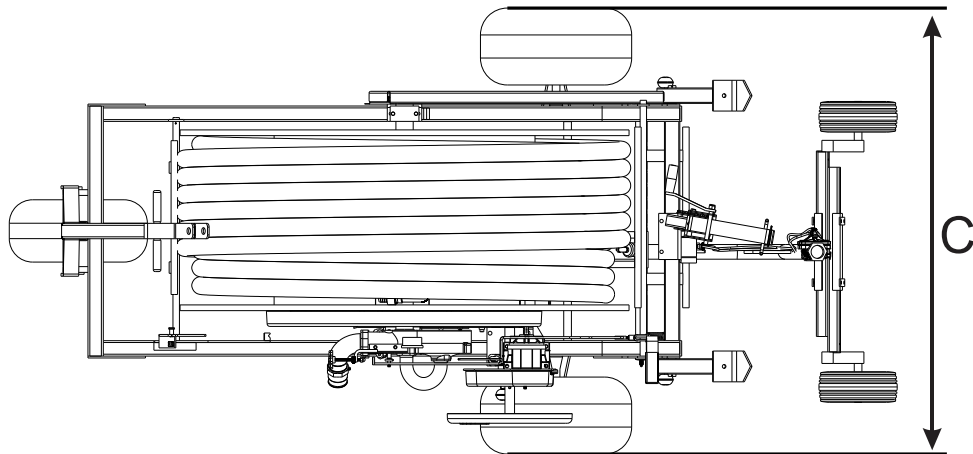



## LIMITED WARRANTY

KIFCO products are warranted to the original user for a period of one year from the date of his purchase invoice, that the equipment will be free from defects in material and workmanship subject to the following conditions:

Satisfaction of this warranty will be limited to the replacement, repair or modification of the equipment involved at the manufacturer's option. The manufacturer's obligation under this limited warranty shall be limited to a credit to the dealer or customer account for the parts or materials required for replacement, repair, or modification of the equipment.

Freight costs shall be paid by the dealer/customer.

This warranty does not apply to certain component parts used on KIFCO equipment. Such component parts are warranted by the original manufacturer and KIFCO'S responsibility is limited to communicating the need for warranty service to each to each manufacturer. Such component parts include, but are not limited to tires, batteries, gearboxes, transmissions, pumps and sprinklers.

This warranty shall be available only if:

KIFCO has received a properly executed delivery record,

KIFCO is notified in writing within 30 days upon discovery of an alleged defect and

KIFCO'S examination of the equipment discloses, to its satisfaction, that such alleged defect has not been caused by misuse, neglect, improper installation, improper operation, improper maintenance, repair or alteration, accident or unusual or extraordinary use demands.

THE FOREGOING WARRANTY SUPERSEDES AND IS IN LIEU OF ALL OTHER WARRANTIES WHETHER EXPRESSED, IMPLIED OR STATUTORY, AND ALL OTHER LIABILITIES OR OBLIGATIONS ON THE PART OF KIFCO, INC.

KIFCO MAKES NO WARRANTY OF MERCHANTABILITY IN RESPECT TO THE EQUIPMENT.

KIFCO MAKES NO WARRANTY THAT THE EQUIPMENT IS FIT FOR ANY PARTICULAR PURPOSE.

### LIMITATION OF LIABILITY

KIFCO SHALL IN NO EVENT BE LIABLE FOR ANY CONSEQUENTIAL DAMAGES (INCLUDING BUT NOT LIMITED TO, DAMAGES FOR INJURY TO THE PERSON OR PROPERTY OR LOST PROFITS) OR ANY INCIDENTAL OR SPECIAL DAMAGES AND/OR EXPENSES, OR CLAIMS FOR INDEMNIFICATION, BY REASON OF ANY DEFECT IN THE EQUIPMENT OR ITS MANUFACTURE, DESIGN OR FUNCTIONING, OR ANY INSTRUCTIONS CONCERNING THE EQUIPMENT.

No agent or representative of KIFCO or any of its dealerships has authority to waive, alter or add to the printed provisions of this warranty and limitations of liability.



700 S. Schrader Ave.

Havana, Illinois 62644

# NOTES

# Dealer Checklist

Owner's Name: \_\_\_\_\_

Address: \_\_\_\_\_

City: \_\_\_\_\_ State: \_\_\_\_\_ Zip: \_\_\_\_\_

Model: \_\_\_\_\_ Serial No.: \_\_\_\_\_ Date Sold: \_\_\_\_\_

## Pre-delivery Checklist: Check below before delivery to customer.

- |         |                                 |         |                        |
|---------|---------------------------------|---------|------------------------|
| ____ 1. | Guards and shields are in place | ____ 5. | Sprinkler Nozzles      |
| ____ 2. | Decals are in place & legible   | ____ 6. | Supply Hose fittings   |
| ____ 3. | Lubrication (Page ____)         | ____ 7. | Touch up paint & clean |
| ____ 4. | Spool Brake adjustment          |         |                        |

## Delivery Checklist:

Review the operator manual with the user and explain the following:

- \_\_\_\_ 1. Kifco warranty policy and claims procedure
- \_\_\_\_ 2. Safe operation and service
- \_\_\_\_ 3. How to operate your Water-Reel
- \_\_\_\_ 4. Speed adjustment and effect on depth of water
- \_\_\_\_ 6. Effect of water pressure on Water-Reel performance
- \_\_\_\_ 7. Winterization and storage procedures
- \_\_\_\_ 8. Give the customer this manual and encourage the customer to read and study the information in the manual

Date Delivered \_\_\_\_\_

Name of Dealer \_\_\_\_\_

Dealer Phone Number \_\_\_\_\_

