



Most Trusted Traveling Irrigation Systems
Since 1964

Kifco Model B110 Water-Reel®



- Bellows Driven Water-Reel® with 1.1" ID x 280' MDPE Tube
- Simple, reliable, portable irrigation for pastures, paddocks, riding arenas, sports fields, vegetables and residential settings
- Automatic shutoff allows for unattended operation
- Mechanical levelwind system with miswrap safety for uniform, reliable tube rewinding
- Rugged construction proven by over 40 years of production and over 35,000 Kifco Water-Reels® sold
- Industry leading products with service and distribution at over 200 authorized dealers

Applicable Markets



Horse Arenas



Pastures & Paddocks



Residential Landscape,
Gardens & Nurseries



Sports Fields

Standard Features and Benefits

- The Kifco Model B110 uses a water powered bellows drive which operates as low as 45 psi and 4 gpm with no additional pressure requirements making it more reliable than small turbines
- Retraction speed control dial provides easy adjustment and setting of application rate
- Sprinkler selector valve easily allows for automatic sprinkler shutoff at the end of the run or continued operation
- Two large flotation tires make transport by hand or small garden tractor simple

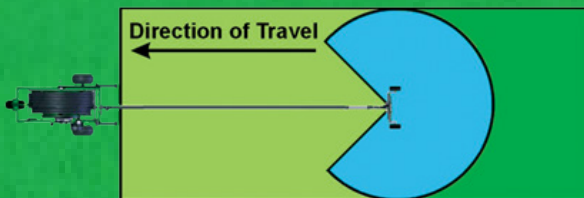

Easy Operation



Local Parts & Service

1 Year
Manufacturer's Warranty
5 Year
Pro Rated Tube Warranty



Engineered in the USA

www.kifco.com



700 S. Schrader Ave.
P.O. Box 290
Havana, IL 62644
800-452-7017 Toll Free
309-543-4425 Phone
309-543-4945 Fax



B110 Dimensions - B2 Chassis

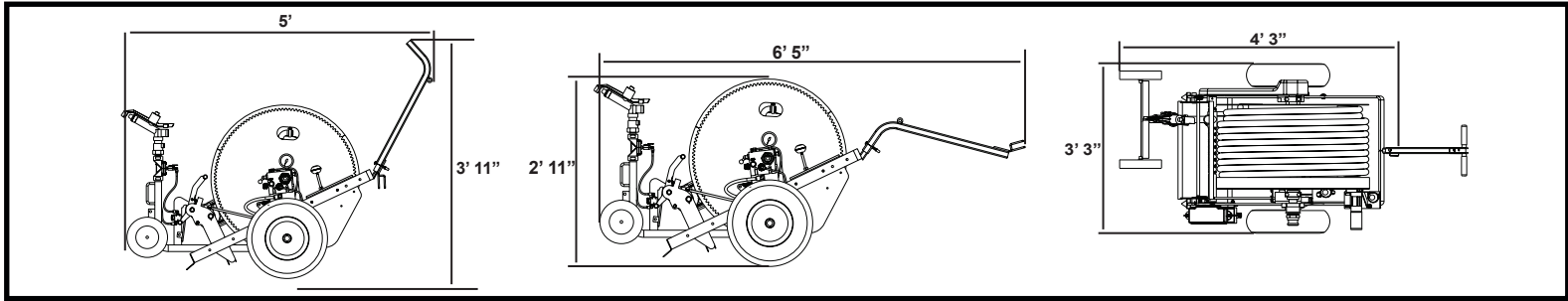

Sprinkler Diagram

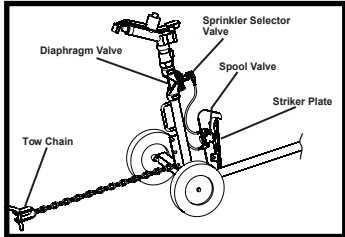

Mechanical Levelwind System

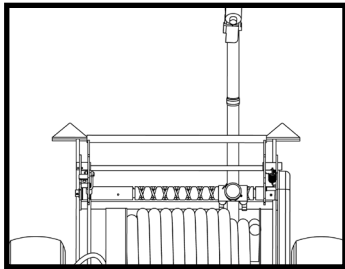

Technical Specifications

Tube Inner Diameter/Length	1.1" x 280'
Irrigated Width	68' - 118'
Irrigated Length	314' - 339'
Irrigated Area Per Run (Acres)	0.5 - 0.8
Drive System	Bellows
GPM Range	4 - 27
Inlet PSI Range	45 - 103
Hours Per Full Run	2.3 - 14
Retraction Speed	20' - 120' Per Hour
Dry Weight (lbs)	276
Weight With Water (lbs)	345
Inlet Diameter	1.5" Male Camlock
Supply Hose	15' 1.5" Male x Female Camlock
Options	
Booster Pump	1Hp Electric Booster Pump (cannot be Reel mounted)
Primary Pump	5.5Hp Gas, 9Hp Gas or 9Hp Diesel

Standard Connection

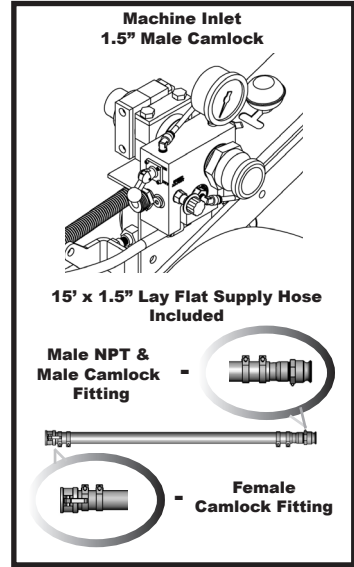

Sprinkler Performance

Sprinkler Model	Nozzle Dia.	Inlet PSI	(Q) GPM	Width (ft.) (80%)	Length (ft.) (80%)	Wetted Dia. (ft.)	Application Rate (in.)
Sime K1	6mm	51	10	78	319	98	0.10 - 0.61
	6mm	68	12	82	321	102	0.12 - 0.71
	7mm	57	14	94	327	118	0.12 - 0.71
	7mm	75	16	96	328	120	0.13 - 0.80
	8mm	65	18	102	331	128	0.14 - 0.85
	8mm	84	20	115	338	144	0.14 - 0.84
	9mm	78	23	108	334	135	0.17 - 1.03
	9mm	103	27	118	339	148	0.18 - 1.10

The K1 8 degree sprinkler is also an option for the B110

Sprinkler Model	Nozzle Dia.	Inlet PSI	(Q) GPM	Width (ft.) (80%)	Length (ft.) (80%)	Wetted Dia. (ft.)	Application Rate (in.)
Sime Silver	4mm	45	4	68	314	85	0.05 - 0.28
	4mm	60	5	78	319	98	0.05 - 0.31
	5mm	48	7	74	317	92	0.08 - 0.46
	5mm	63	8	84	322	105	0.08 - 0.48
	6mm	52	10	78	319	98	0.11 - 0.64
	6mm	68	12	76	318	108	0.13 - 0.75

Area covered may vary depending on wind conditions and use of different sprinklers. Specifications are subject to change without notice. Technical specifications contained herein are based upon sprinkler manufacturer's recommended pressure and flow. Actual specifications may vary. Bellows Flow approximately .17 to 1.31 gpm.

The B-110 Water-Reel can irrigate a football or soccer field in two passes

