

# Turbo

**Innovative self-cleaning technology**

**UNINTERRUPTED  
IRRIGATION WITH  
EFFORTLESS  
CLEANING!**

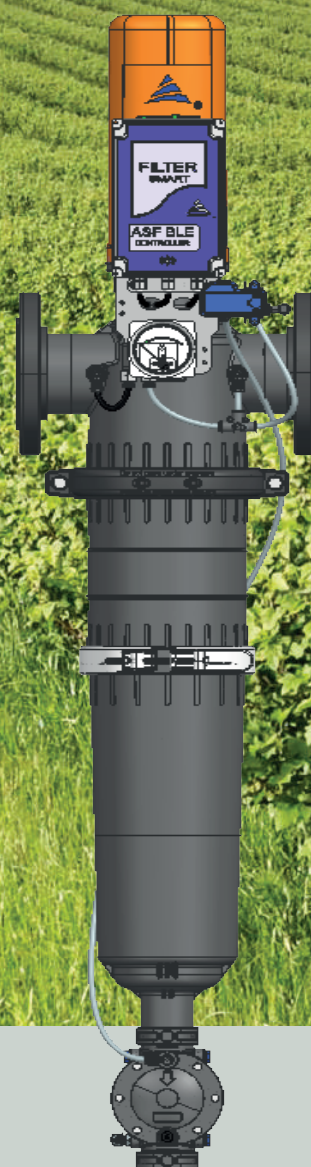

**Automatic Screen Filter**  
with Smartphone operated BLE-Controller

# TABLE OF CONTENTS

## **Technical Specifications**

### **General Instructions**

Hydraulics

Downloading “Filter Smart” App

### **Unpacking**

### **Installation**

General Instructions

Installation Layouts

Installation Procedure

Controller wiring layouts

### **Initial Operation**

### **User Manual for “Filter Smart” Controller**

General features

Application screen data

Navigation buttons

### **Maintenance**

General Safety Instructions

### **Maintenance Schedule**

Once a Week

At the end of irrigation season

Winterization

### **Cleaning Procedure**

Manual Cleaning Procedure

Chemical Cleaning Procedure

### **Filter Disassembly**

### **Troubleshooting**

## Technical Specifications

General data	2"/2.5" TURBO 800	2"/2.5" TURBO 1200	3" TURBO 1200	3" TURBO 1600	4" TURBO 2000	4" TURBO 2400
Connection Size & Type	2" /50mm & 2.5" /65mm (Threaded (BSP/NPT)/Grooved)		3"/80mm Threaded(BSP/NPT) / Flanged/Grooved		4"/100mm (Flanged/Grooved)	
Max. Flowrate *( 130 micron)	25 m <sup>3</sup> /hr (110 gpm)	30 m <sup>3</sup> /hr (132 gpm)	40 m <sup>3</sup> /hr (176gpm)	50 m <sup>3</sup> /hr (220 gpm)	70 m <sup>3</sup> /hr (308 gpm)	80 m <sup>3</sup> /hr (352 gpm)
Maximum Operating Pressure	10 Bar/145 psi				8 Bar /116 psi	
Min. Recommended Flushing Pressure	2 Bar/30 psi					
Max. Operating temperature	60 C/(140 F)					
Filtration Surface Area cm <sup>2</sup> /inch <sup>2</sup>	831 cm <sup>2</sup> / 129 inch <sup>2</sup>	1270 cm <sup>2</sup> /197 inch <sup>2</sup>		1662 cm <sup>2</sup> / 258 inch <sup>2</sup>	2101 cm <sup>2</sup> / 326 Inch <sup>2</sup>	2540 cm/ 394 Inch <sup>2</sup>
Material of Construction	All Polymeric / EPDM / St.St.					
Available Filtration Degree Mesh (Micron)	80 (200 )/120(130)/150(100)					

## Control and Electricity:

Rated Input Supply (To Controller)	24V DC
------------------------------------	--------

\* Depends on water quality.

## Head Loss Chart

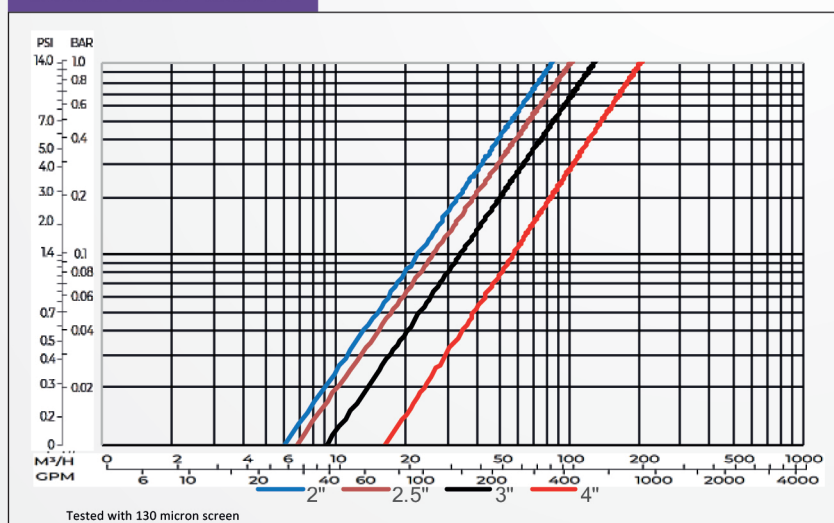

## Dimensions

Dimensions (cm/inch)	Turbo 800	Turbo 1200	Turbo 1600	Turbo 2000	Turbo 2400
A	37/14.5"			40/16"	40/16"
B	62.5/24.5"	71/28"	83.5/32"	100/40 "	112/44"
C	111.5/45"	120/47"	132.5/52"	150/59"	163/65"

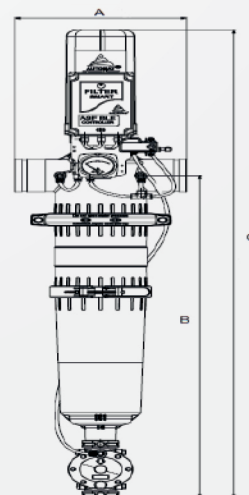

## General Instructions

**Attention:** Read the installation and operation manual carefully before handling the system.

- While working with the filter all conventional safety instructions should be observed in order to avoid danger to the person handling the system, the public or to the property in the vicinity.
- DO NOT make any changes or modify the filter equipment without any written permission from the manufacturer or by its representative.
- Always use original spare parts supplied by the manufacturer.
- Always open and close isolation valves (if installed) at upstream and downstream gradually to prevent water hammering.
- Air release valve should be installed in the system to release the air / break vacuum.
- To avoid damage or breakage, the filter, including the cover and command tubes, must be drained prior to frost periods.
- Use rated power input for the controller as given in technical specifications.

### Hydraulics

- We recommend to install suitable upstream and downstream isolation valves.
- The diameter of the upstream pipe must not be smaller than the filter inlet.
- It is recommended to install a pressure relief valve before the filter to protect the upstream line and filter from pressure surge.
- During the flushing process, a minimum pressure of 2 bar (30 psi) should be maintained at the inlet of the filter for efficient cleaning. In the event that the system cannot maintain the required flushing pressure, a pressure sustaining valve should be installed downstream of the filter.
- Please note that In case there is a chance of back flow, a non-return valve should be installed at downstream of the filter to avoid damage to screen.
- Flushing line should not be reduced after the flush valve or should not be too long that it creates back pressure on the filter. This can affect cleaning of the filter during flushing.

### Download the “FILTER SMART “app in your smart phone to operate this filter

Go to Google play store in case of Android phone or IOS store in case of iPhone, search & install “AUTOMAT FILTER SMART” application on your smart phone.

OR

Go through the below link & “QR CODE”



Please scan QR code for download the application (ANDROID)



Please scan QR code for download the application (IOS)



## Unpacking

**Step 1:** Cut the strips with suitable cutter & Open the box and download “FILTER SAMRT “ App on your smart phone by scanning QR code given on the box or by Google play store in case of Android phone or IOS store in case of iPhone.



MDF Support



Flush Valve

Power Supply Unit

**Step 2:** Remove the wood board with help of screw driver ( open the screw)

**Step 3:** Take out the flushing valve and the power supply unit box



Wood board



Flush Valve

Power Supply Unit

**Step 4:** Pull out the MDF support supporting the motor cover and the controller.

**Step 5:** Pull out the filter from the box by holding the strips.

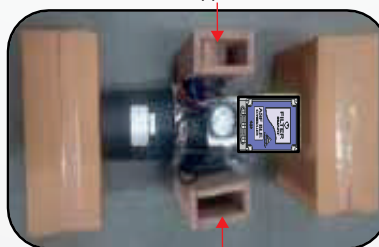
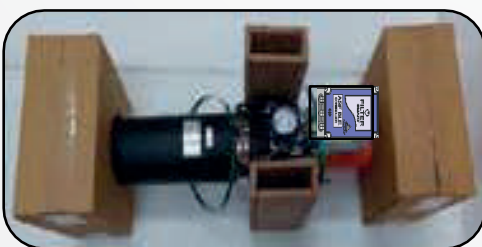

Supports

Remove Corrugated support boxes



**Step 6:** Cut the strips and slide away the supports and corrugated box.



**Attention**

**Do not pull out the filter by holding connecting tubes, DP switch, controller plate or the motor cover. It may damage the filter.**



**Step 1:** : Insert the Victaulic flange first on filter body Victaulic connection groove with counters out side .

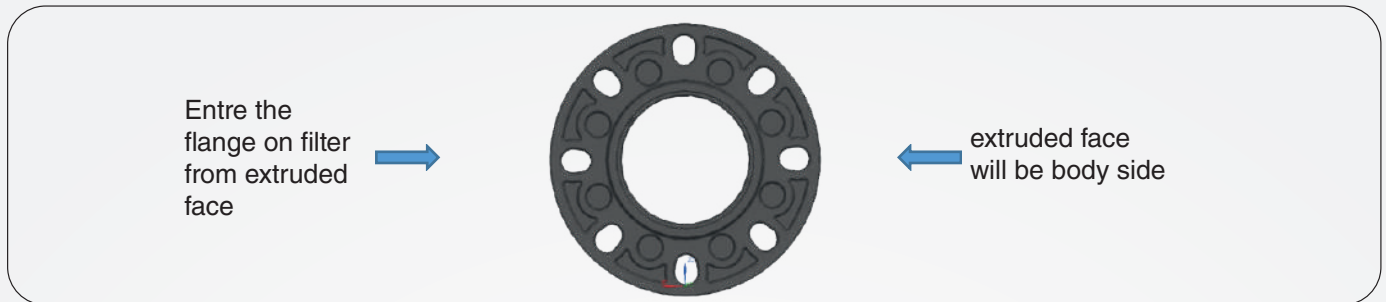

**Step 2:** Insert C-Clip in the groove to keep the flange locked and prevent falling off the filter connection.



**Step 3:** Insert the rubber gasket onto the groove and pull the flange towards the C-Clip, locking the flange in place.



## INSTALLATION

### General Instructions for Installation

- Make sure to install the filter in the direction of flow arrow marked on the filter .
- Ensure you have enough space around the filter assembly for easy maintenance.
- Electric wiring should be done using standard and approved components by a qualified electrician only.
- Avoid direct water splash on electrical equipment.
- Filter system should be supported appropriately.
- Use recommended tools for installation and maintenance.
- Download "FILTER SMART" App to your smart phone as given below.

## Recommended Installation layouts for 4"-Turbo 2000 & 2400

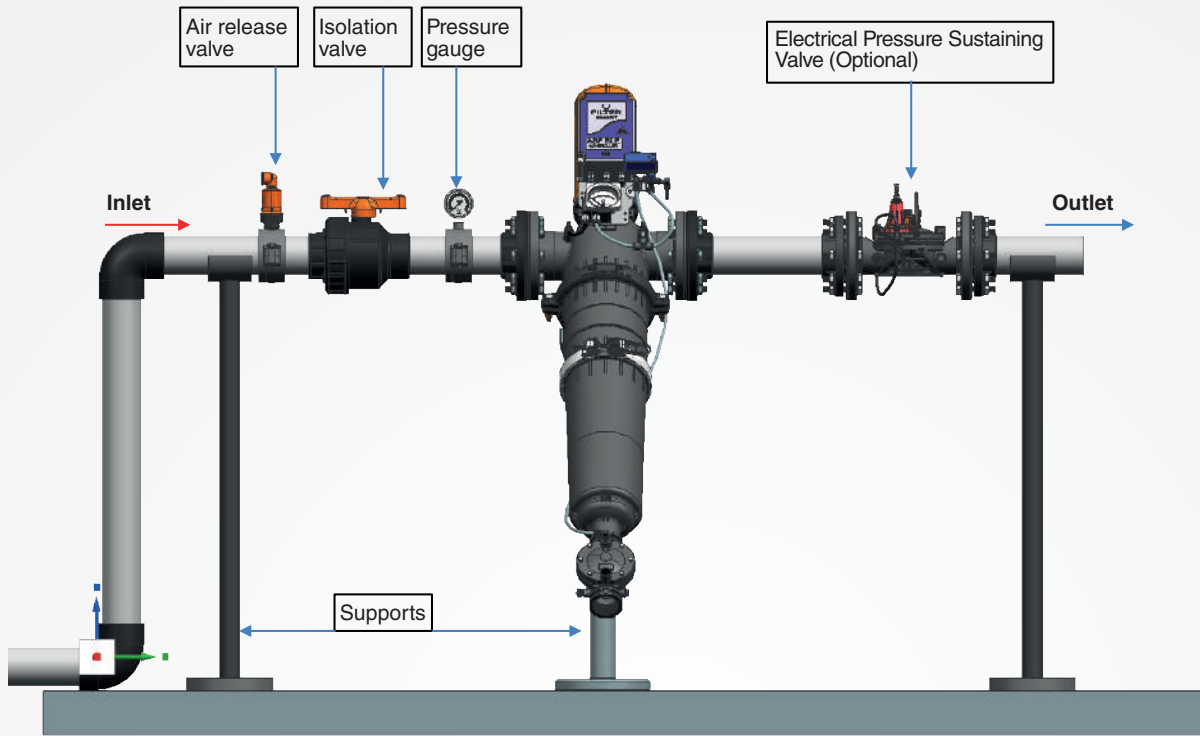

## Recommended Installation layouts for 2", 2.5" & 3"-Turbo 800, 1200 & 1600

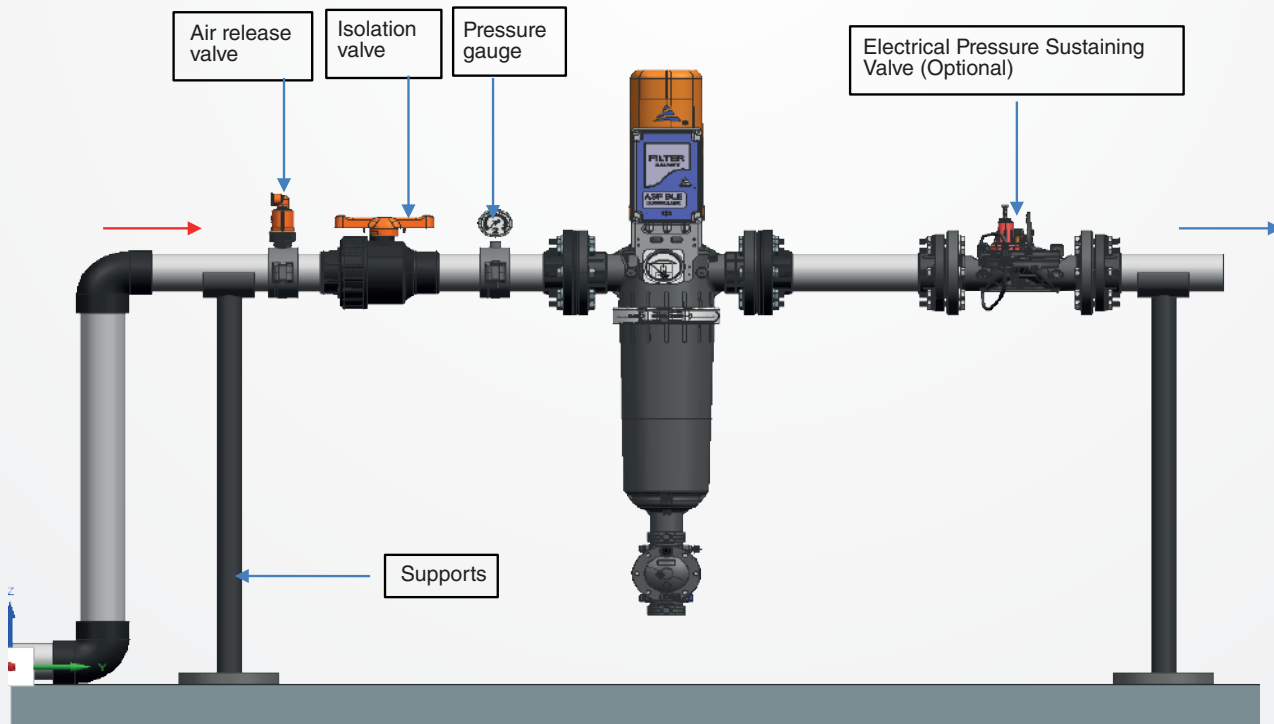

## Installation Procedure

### Step 1

Install filter on the line with the help of suitable tools as shown above layouts depending upon models .

### Step 2

Connect open end of connecting tube(A) with flush valve control chamber with help of ¼” elbow

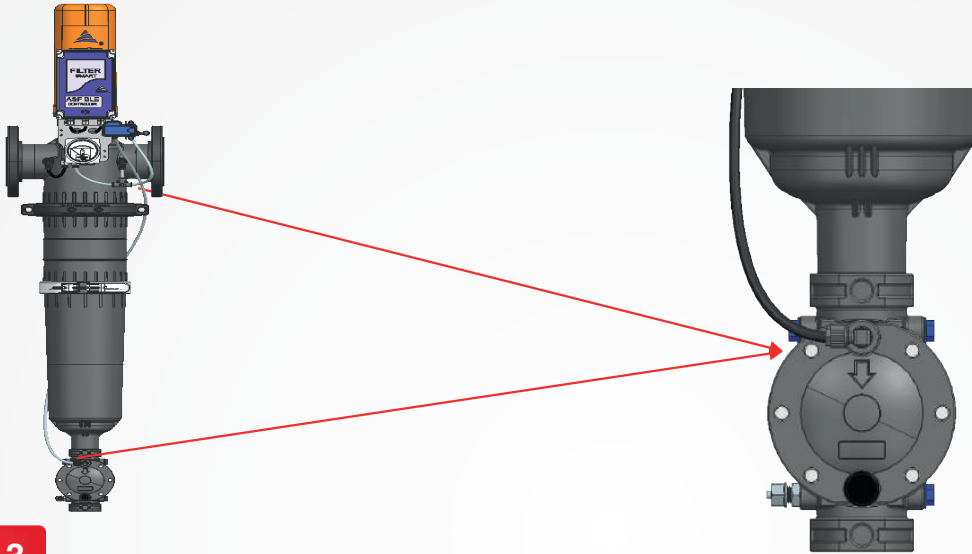

### Step 3

Connect 24V DC power male connector to the “ female Power” connector ‘P’ on the controller.

For correct and easy identification, the controller wires are colour coded for polarity. The red wire is (+) and the black is (-). Positive (+) & negative (-) wires of 24 VDC, 5 amp. supply to be connected positive (+) with Positive (+) & Negative (-) with negative (-) .

## CONTROLLER WIRING LAYOUT

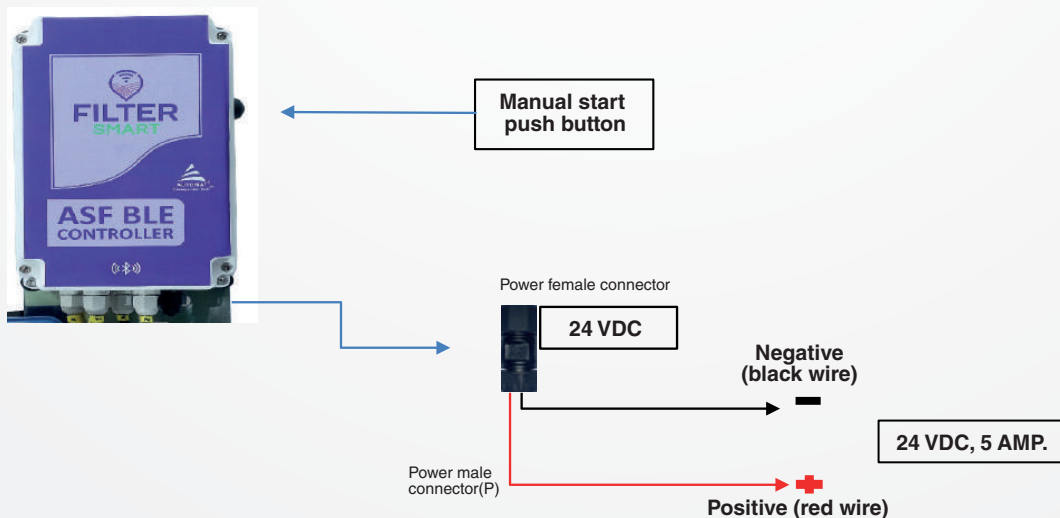

The polarity of connecting wires [red (+) and black (-)] is important for the direction of rotation of the motor and the suction scanner. Make sure to connect as per color coding.

## CONTROLLER WIRING LAYOUT WITH ADAPTOR:

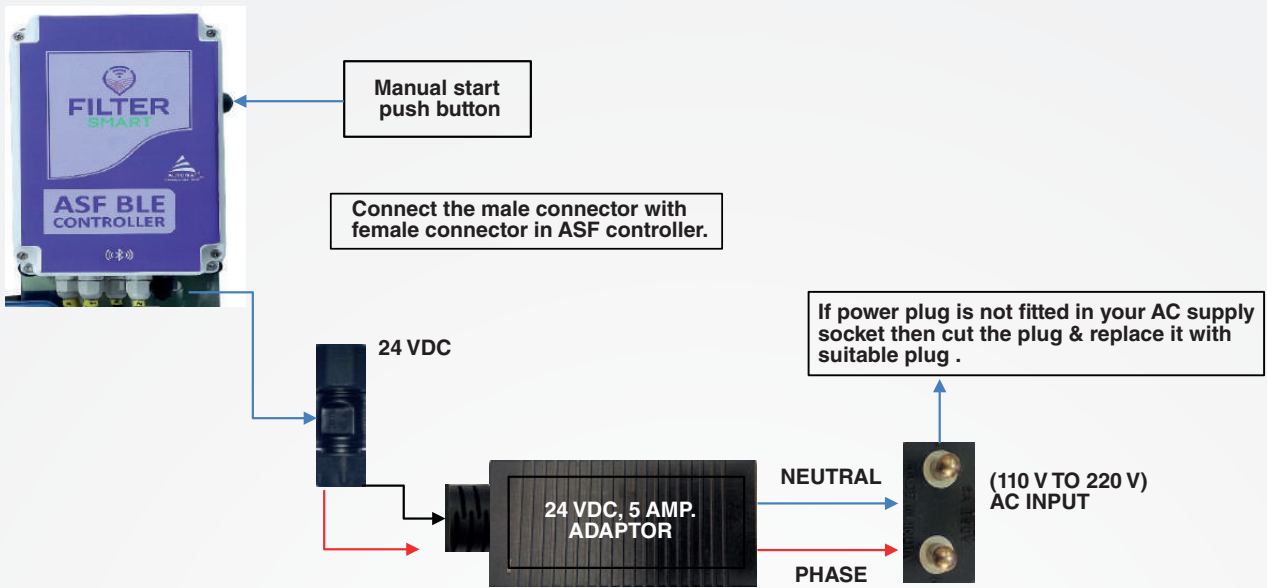

## CONTROLLER WIRING LAYOUT WITH SOLAR:

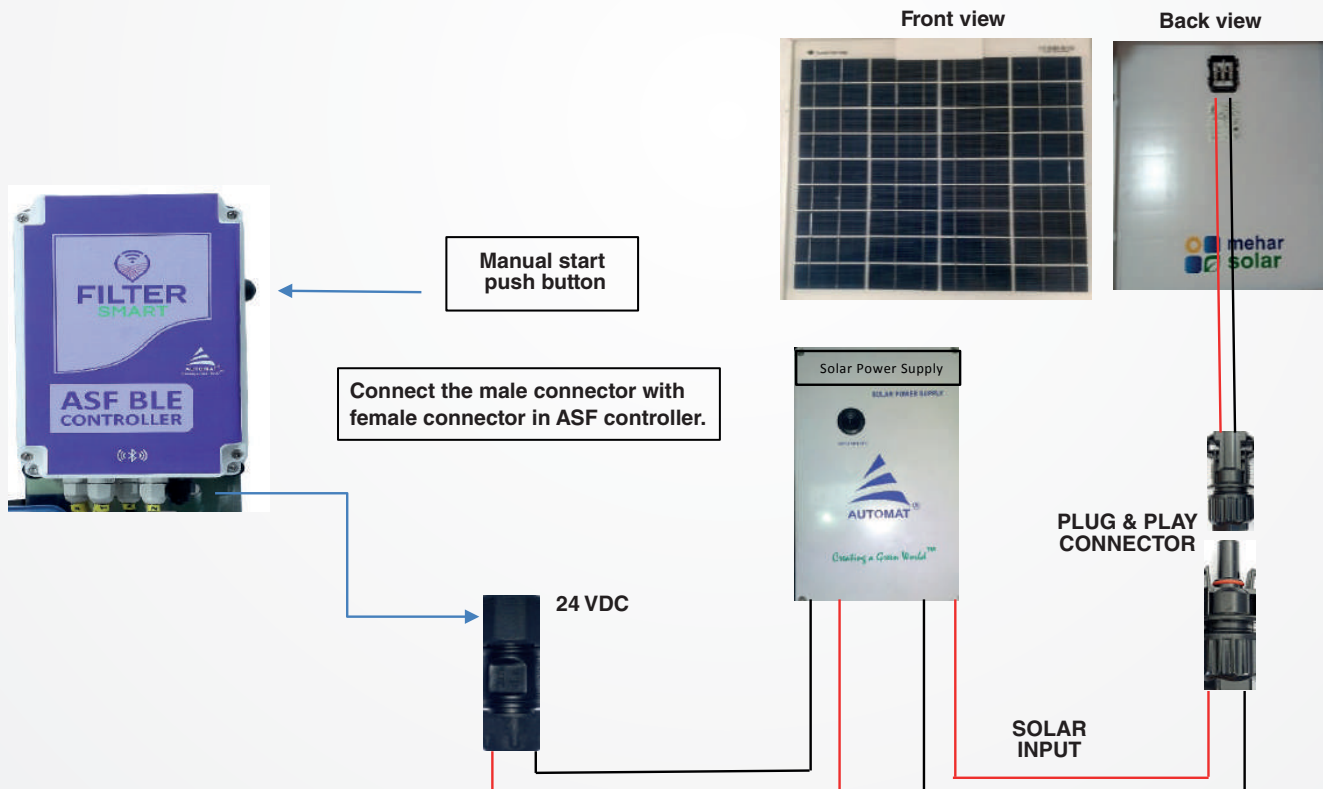

## CONTROLLER WIRING LAYOUT WITHOUT ADAPTOR:

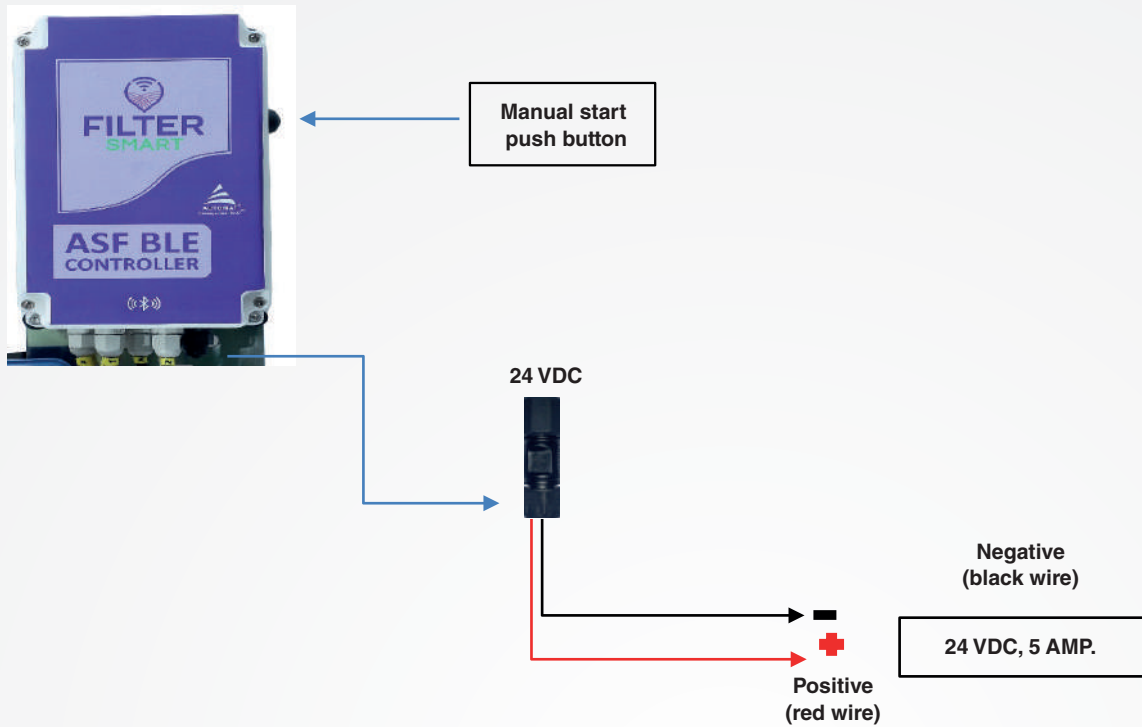

### Electrical Layout Details

Legend	Description	Remarks
P	Power Input (To Controller)	Input to controller
Red Wire	Positive (+) – 1 sq mm.	Connect with port 'P' (red wire).
Black Wire	Negative (-) – 1 sq mm.	Connect with port 'P' (black wire).
D.P.	Differential Pressure	To connect differential pressure gauge. Factory fitted.
V-1	Valve 1	To operate flush valve (V-1, 12-24 V DC latch). Factory fitted.
V-2	Valve 2 (Optional)	To operate pressure sustaining valve.
M	Motor	To operate the motor. Factory fitted.

Now Filter is ready for operation

## Initial Operation

- Carefully read this operation manual prior to operating the filter.
- Only a qualified technician should commission the filter.

For initial operation (or operation after maintenance) follow the below steps:

### Step 1

start the pump / Open the inlet valve slowly while the outlet valve remains closed .

### Step 2

Once the system is pressurized, check for any leakage through filter and connections.

### Step 3

Initiate a manual flushing cycle by long pressing the “MANUAL” button provided on the controller (for 5 seconds). This will open the flush valve and cleaning will be initiated.

Repeat this step for 2 to 3 times to evacuate air from the system and check proper functioning of the filter . Open the downstream valve gradually allow all downstream lines completely fill-up to build-up pressure in the entire system . Now flush filter again by activating manual flushing icon on mobile screen & now check the upstream pressure during the flushing cycle. Ensure it does not drop below 2 bar ( 30 PSI) for efficient cleaning of the filter during flushing . Use pressure sustaining valve (Optional)at filter outlet if required.



Manual push button



#### Attention

The controller comes pre-set with default operating values. Do not change without consulting Automat technical team. Please refer to “FILTERSMART” user manual for more details.



## User Manual: “FILTERSMART” Controller



### Table of contents

- Safety instructions
- General description
- General Features
- Flushing methods
- The User Interface panel
- Programming
- Monitoring
- Controller wiring layout
- Handling faults
- Warning

### Safety Instructions

- Prior to operating the controller please read carefully the instructions given in this manual.
- Use this controller for “Turbo” filters operation only. Any misuse may damage the controller and affect your warranty coverage.
- Do not leave the wires loose, use cable ties to fix them properly.
- Electric wiring should be done by a qualified electrician only & use standard components for it.
- Avoid water splash on electrical equipment's.
- Ensure proper earthing to avoid damage to controller or power supply unit.
- Ensure input voltage to the controller is 24V DC,(+/- 2 volts) 5 amp.

### General Description

The “FILTERSMART” controller commands the flushing process of the Automatic “Turbo” series filters offered by Automat. The controller is configured to pre-set parameters, to enable the operation and monitoring easy & simple thus offering reliable & long-term operation.

## General Features

### Inputs

- Input to the controller : 24 VDC, 5 ampere.
- Equipped to operate 1 to 5 filters with 12-24 VDC Latch solenoid coil and 24 VDC, 2.8 A , electric motor
- External digital differential pressure gauge (bar/psi).
- Controller & External Switch are IP65 protected
- Operating temperature (0-60 degree C)

### Outputs

- V1 - Flush valve (12-24V DC LATCH TYPE)
- V2 - Downstream valve (Electric Pressure Sustaining – 12-24V DC LATCH TYPE, optional)
- Motor - 24V DC

### Looping

- The controller signals looping alarm after set consecutive flush cycles triggered by pressure differential across the filter. Default Value 5 . Adjustable range 1 to 10

### Default Set Parameters

- Flushing Duration: 15 seconds
- Time Based Flushing: 240 min
- DP Delay: 1 second
- Set DP: 0.50 bar
- Looping Cycles: 5
- Downstream Valve: Off
- Mode: DP & Time
- Dwell Time: 2 Sec (Applicable In case of multiple filters only)

### Flushing Methods

- Flushing triggered by DP & Time (by Default)
- Flushing triggered by DP Only.
- Manual flushing.

## Application Screen Data

When you tap on “FILTER SMART” icon following screen will appear on your phone

### Step 1

Choose your language & press add filter icon (Image 1)

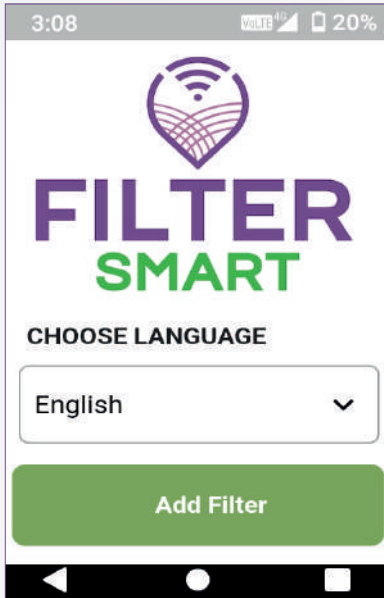

### Step 2

Activate Bluetooth ,location & click to scan filter (Image 2)

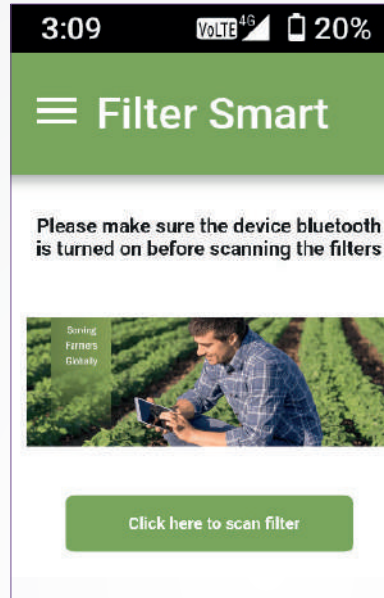

### Step 3

Put the pairing password “12345” to pair with controller (image 3)

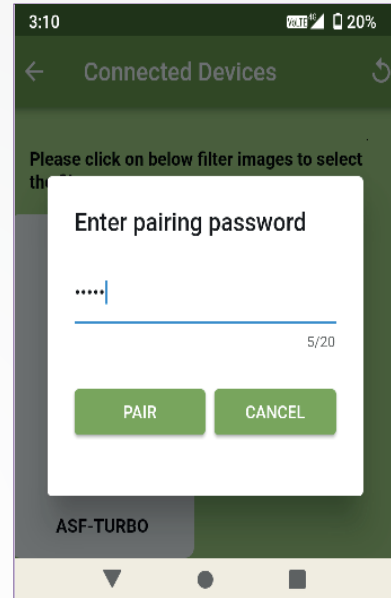

### Step 4

Click on the operation screen icon (image 4)



### Step 5

You will come to operation page (Image 5) .

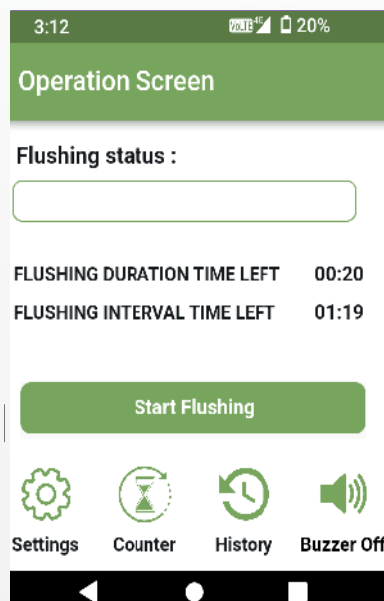

## NAVIGATION BUTTONS



**Counter**



**History**



**Buzzer Off**

The navigation buttons have been designed to get quick access to different screens like Settings, Counter, History, and Buzzer off.

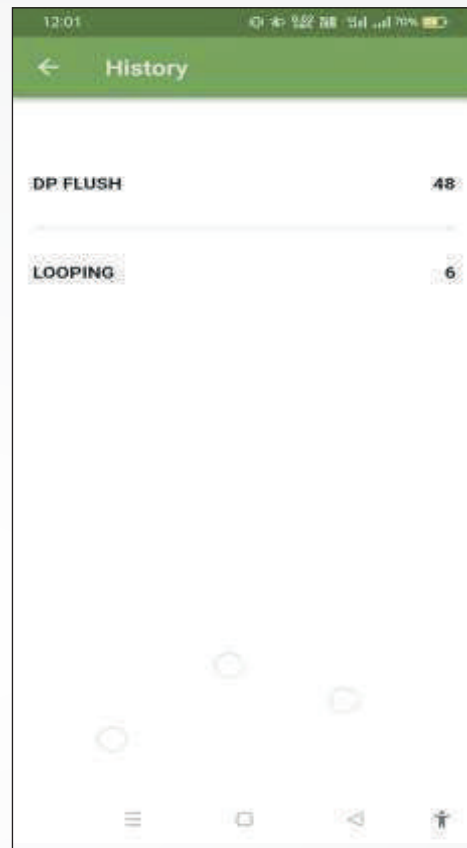
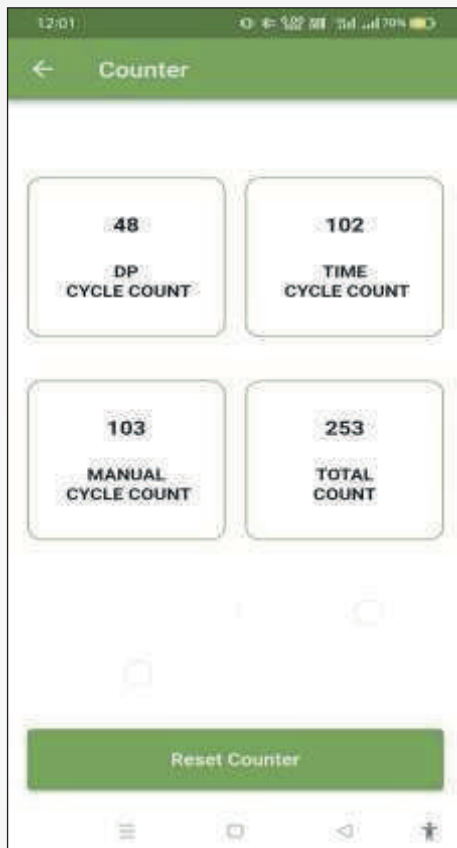

### Settings

Shows Setting pages to change settings (controller is pre-programmed with default values from the factory & we strictly recommend not to change these settings). In special case if any change is required in default settings, please contact us before doing any change in the settings.

### Counter

Shows total no of flushing cycles done & flushing counts of different flushing modes separately. (DP Only/ DP & Time / Manual) . See counter screen as shown above.

### History

Shows history of DP flushing's and looping error counts. See the History screen shown above.

### Looping Buzzer off:

Shows the maximum consequent back flush cycles triggered by high DP, controller enters in to looping mode and gives **buzzer alarm on the mobile screen in red colour** & beep sound from the controller, it is the indication that filter to be clean manually. To switch of the buzzer click on the buzzer off icon. After reset it will again change its color from red to Green.

Default value for consecutive cycles is 5 & Adjustable range is 1-10 cycles.

## Maintenance

### General Safety Instructions

- Installation, operation, and maintenance should be performed in accordance with instructions described in this manual.
- A general inspection of the filter operation should be done regularly and prior to any scheduled maintenance. This includes seasonal and post season check-ups.
- When under pressure, the filter may start a flushing cycle automatically at any time, without prior indication.
- Do not perform any maintenance work or try to open filter parts when the filter is in pressurized condition.

### Maintenance Schedule

#### Once a Week

- Visually inspect the filter and parts for leakage. Repair if necessary.
- Perform 2 to 3 manual flushing of the filter.
- Make sure that during the flushing cycle the inlet pressure does not drop below 2 bar.
- Ensure the PD is back to normal. In case of high DP, close the downstream valve and initiate a manual flush command. If the DP still does not get back to normal, a manual cleaning of the screen may be required.

#### At the end of irrigation season

- Close the downstream isolation valve.
- Perform 2 to 3 manual flushing of the filter.
- Turn off the pump and close the upstream isolation valve.
- Drain the filter by opening the end plug provided at the inlet of flushing valve .
- Visually inspect the filter, O-rings and seals for any damage. Replace damaged ones if necessary and apply Silicone Molykote OKS111 grease for lubrication. Perform chemical cleaning of the screen(Refer to screen cartridge cleaning instructions given in this manual.)

#### Winterization

To avoid damage or breakage, the filter, including the cover, valves and command tubes, must be drained prior to frost periods. Filter operation should be suspended in climates where the filter is exposed to freezing temperatures.

#### Cleaning Procedure

During the operation, if the filter runs into flushing frequently and the looping alarm does not subside, it indicates that the screen is clogged. In this situation, the screen cartridge needs a manual or chemical cleaning ,if manual cleaning doesn't work.

#### Manual Cleaning Procedure:

- Switch off the buzzer alarm by pushing red buzzer icon .
- Close the downstream valve and do the manual flushing twice .Even after that looping does not subside then manual is required .
- Remove the screen cartridge (Refer to filter disassembly procedure).
- Remove the O-Rings from screen cartridge .
- Now take clean water in bucket and dip the screen in it.
- With the help of brush (with nylon bristle), clean the internal surface of the screen.
- Now wash the screen by applying high pressure water jet from outside.
- If the impurities have deposited and do not get removed by manual cleaning and high pressure water jet, a chemical cleaning of the screen is required.



### Chemical Cleaning Procedure

- Follow steps (3) and (4) given in manual cleaning procedure.
- Prepare a solution containing 7 liters of water and 3 liters of 10% HCL.
- Dip the screen in this solution for 2-3 hours.
- Now take out the screen and wash it with a jet of fresh water as shown in manual cleaning steps.
- Reinstall O-Rings as before.
- Reinstall screen cartridge in the filter.



Take care while handling acids and chemicals; wear suitable hand gloves, shoes, full sleeve top, trousers and eye protection gear.

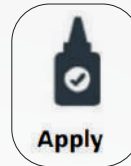

Before installing the screen cartridge, ensure to apply grease on the O-Rings.

## Filter Disassembly

In an event to replace the filter screw, follow the steps given below

### Step 1

Remove the command tube connected to the control chamber of the flush valve and the solenoid.

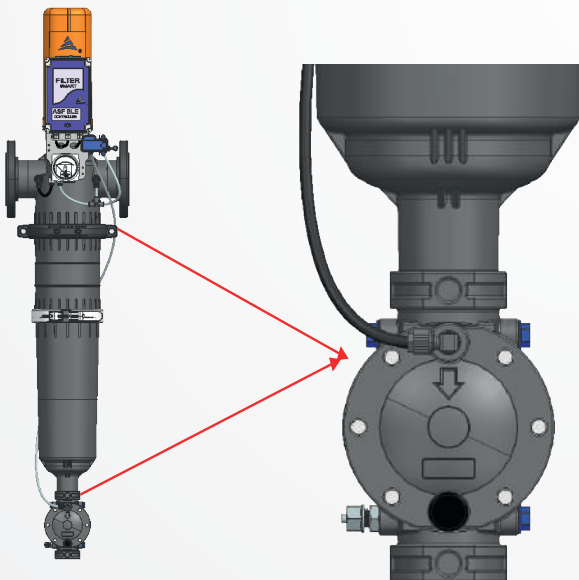

### Step 2

Drain the filter completely by opening the end plug provided at the upstream of flushing valve.

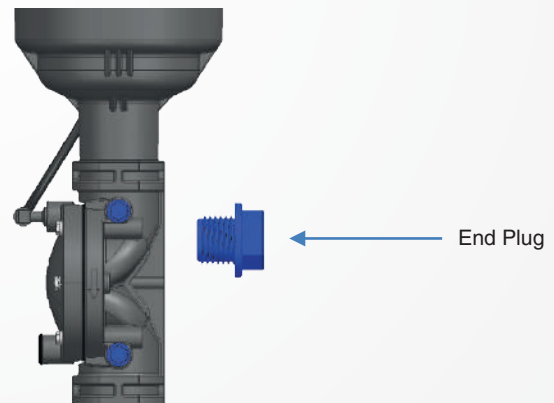

### Step 3

- Open the clamp and remove the filter cover carefully.
- Now pull the screen cartridge downwards gently without affecting the suction scanner assembly.

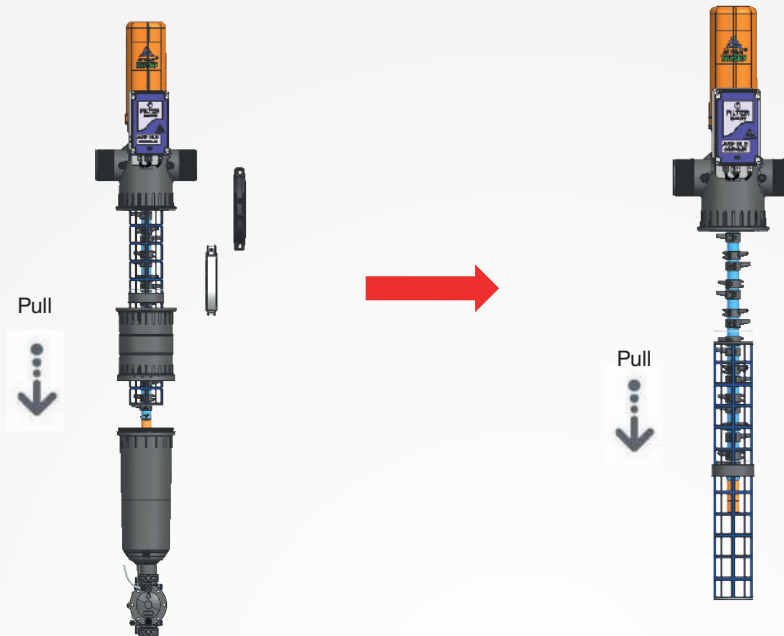

### Step 4

Open the screws of the motor cover from both side & carefully pull up the cover vertically.

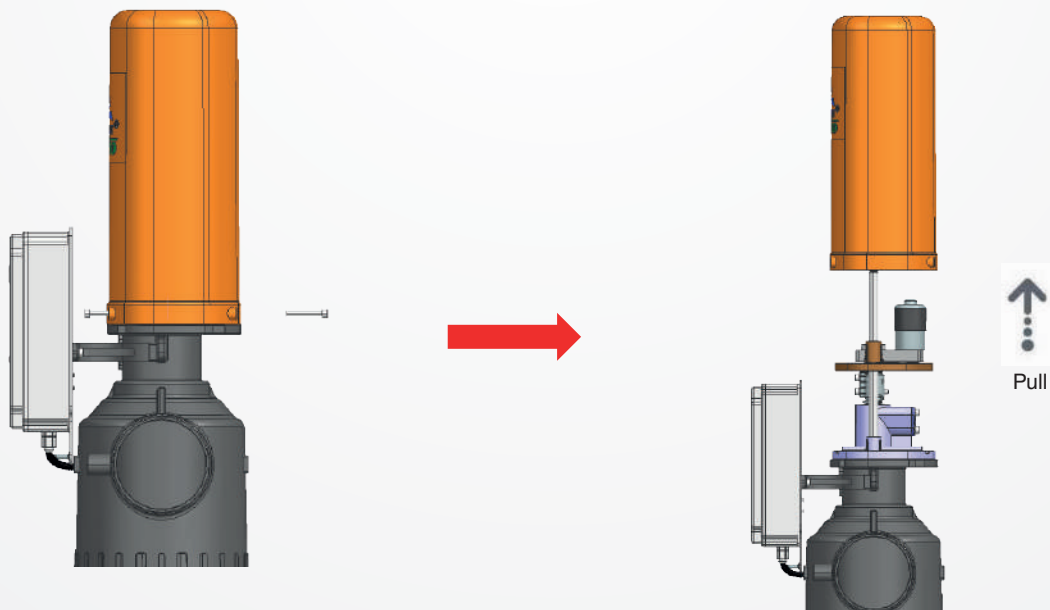

## Step 4

Open the screw 2 with the help of allen key. This screw couples the drive shaft with the motor.

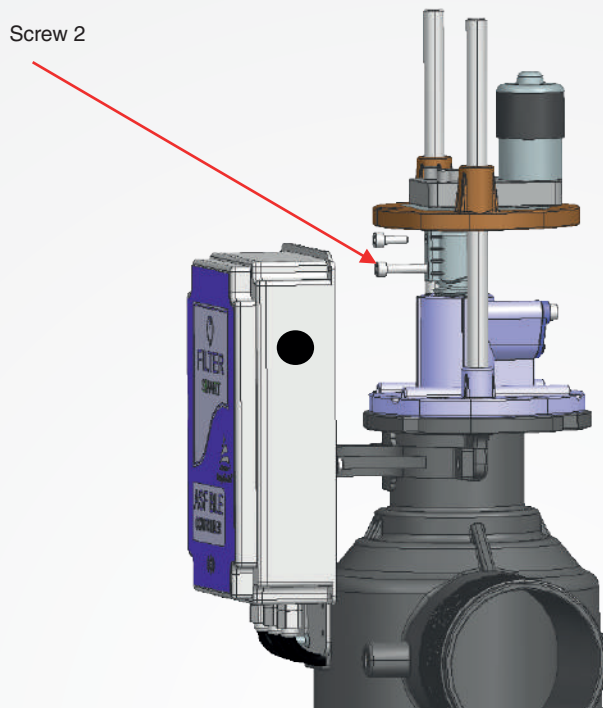

## Step 5

Pull the motor mounting plate along with motor upwards carefully; disengaging the motor assembly from the filter.

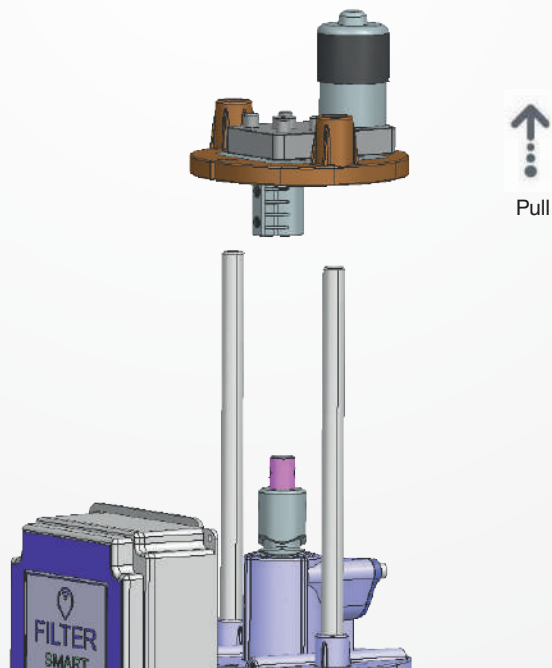

## Step 6

a. With the help of a suitable pin & plastic/rubber hammer, remove dowel pin connecting the drive shaft and the reversing screw. This will free the driving shaft and suction scanner assembly connection from reversing screw

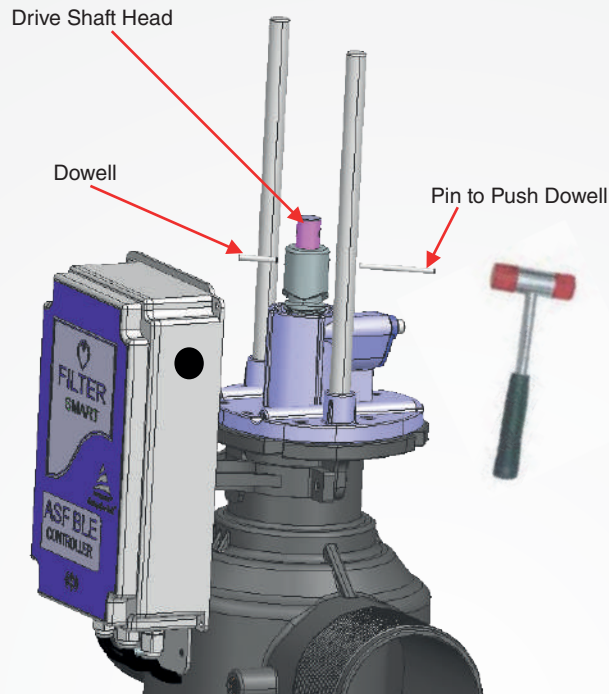

b. Hold the suction scanner from bottom by one hand & hammer on the drive shaft from the top to loosen the drive shaft and suction scanner assembly. This will enable to pull the suction scanner from below.

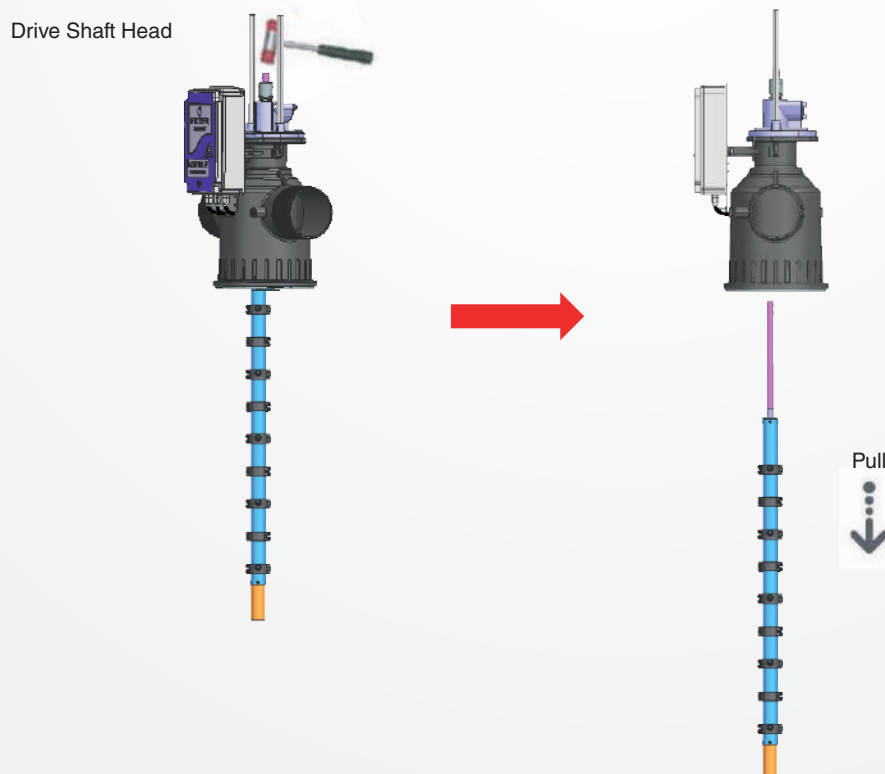

## Step 7

a. Unscrew pressure balancing unit by rotating it in anticlockwise direction to unscrew it from screw housing and take out from the filter body by suitable tool/fixture.

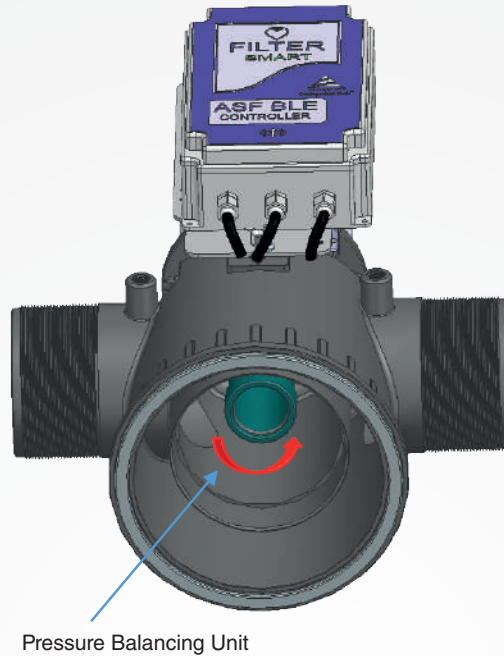

b. Ensure the cup seal and O-Ring are not damaged. Replace if needed. While reassembling, apply grease.



## Step 8

Disassembly of the reversing screw.

- a. First, unscrew the allen bolts of the follower cover. This will disengage the follower from reversing screw. Now slightly rotate the reversing screw by hand. This will push the follower outwards. Take out the spring & follower.

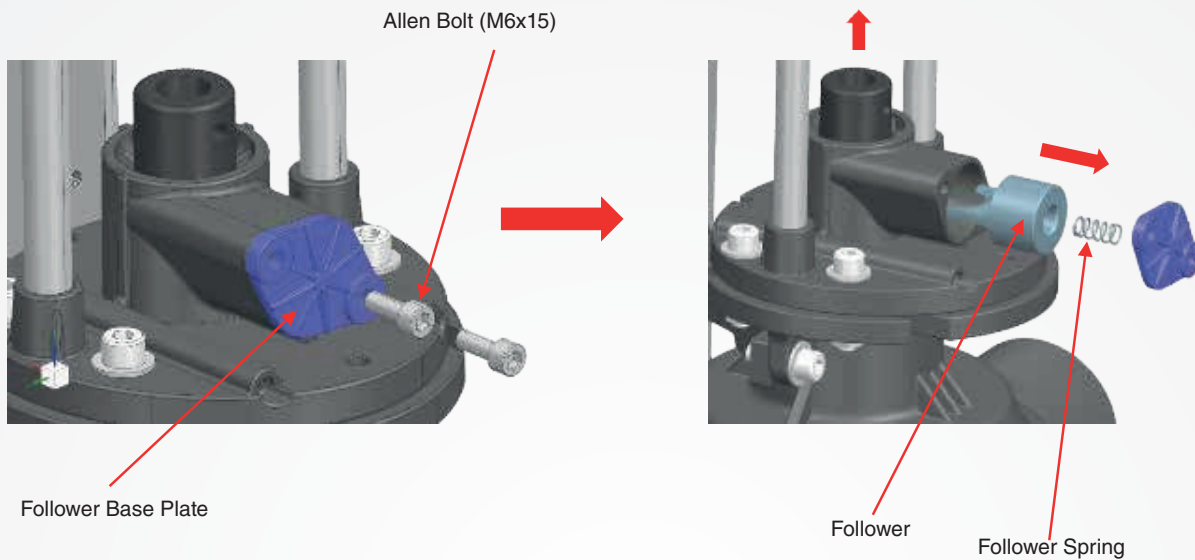

8b Pull the reversing screw upwards.

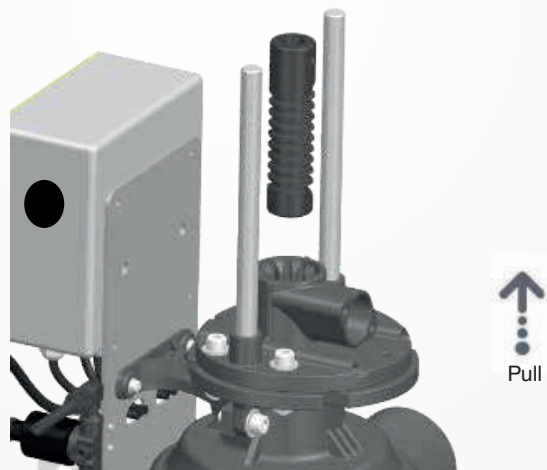

### Assembly Procedure

*Before Reassembly:*

- Make sure all the parts are undamaged.
- Replace damaged gaskets, O-Rings, Nozzles & Teflon washer .
- Make sure the screen cartridge is clean & undamaged. In case screen cartridge is damaged, replace it with new screen cartridge.
- Apply silicone grease on O-Rings and Gaskets (Silicone Molykote OKS 111). 5) Re-Assemble parts as before.
- During Assy of Reversing screw ,follower ,make sure that follower should match with screw threads & movement should be smooth .
- After fitment of suction scanner ,screw & follower assy ,check the rotation/movement of suction scanner assy by rotating it by hand then assembled the cover .



## Troubleshooting Guide

Problem	Cause	Solution
High pressure differential across the filter.	Screen cartridge is clogged	1. Perform a manual flush cycle. Follow the steps given below.
		a Close the downstream isolation valve.
		b Press “Manual” button on controller for 5 seconds to initiate the cycle. Repeat the step twice.
		c Open the downstream isolation valve and verify the downstream pressure is slightly lower than the upstream pressure.
		If the problem persists, perform a manual / chemical cleaning of the screen cartridge which ever is required . For details, refer to “Manual/Chemical Cleaning Procedure” given in this manual.
Frequent flush cycles.	Water quality has changed.	Check the source water quality for poor quality conditions.
	Screen cartridge is clogged.	Perform a chemical cleaning of the screen cartridge. For details, refer to “Chemical Cleaning Procedure” given in this manual.
	Faulty DP Gauge (Erratic pointer or switch action).	Check if DP gauge is working properly. Erratic pointer or switch action may indicate the cleaning is required. Please refer to “Handling Faults” in Controller Functions given in this manual.
Filter not flushing automatically.	No power supply to the controller.	Check power supply (or fuse) to the controller. Replace the fuse if faulty.
	Faulty DP Gauge	Check if DP gauge is working properly. Erratic pointer or switch action may indicate the cleaning is required. Please refer to “Handling Faults” in Controller Functions given in this manual.
	Faulty/Blocked Solenoid.	Dismantle and clean the solenoid. Check for “click” by supplying rated input (24 VDC). Replace the solenoid if faulty.
Flush valve remains open.	“Manual Override” not pointing towards auto port	Turn “Manual Override” of solenoid to auto position.
	Blocked in-line finger filter.	Disconnect upstream tube and check for firm water stream. Clean or replace the finger if required.
	Debris on sealing seat (valve is continuously discharging small amount of water).	Manually operate the solenoid coil and let it remain open for sometime. If the problem persists, dismantle, clean and check that valve parts are not damaged.
	Damaged diaphragm (continuous water discharge).	Replace the diaphragm.
Controller does not start	Improper voltage supply	Check for 24VDC (+/- 2 ) volts coming to the controller.
Setting	Need default setting change	Contact to your nearest dealer or company representative

## To be pasted on outer box

HOW TO DOWNLOAD, INSTALL & USE THE “FILTER SMART” APPLICATION

### INSTALLATION OF “FILTER SMART” APPLICATION ON ANDROID AND IOS PHONE

Go to Google play store in case of Android phone or IOS store in case of iPhone, search & install “FILTER SMART” application on your smart phone.

OR

Go through the below link & QR CODE

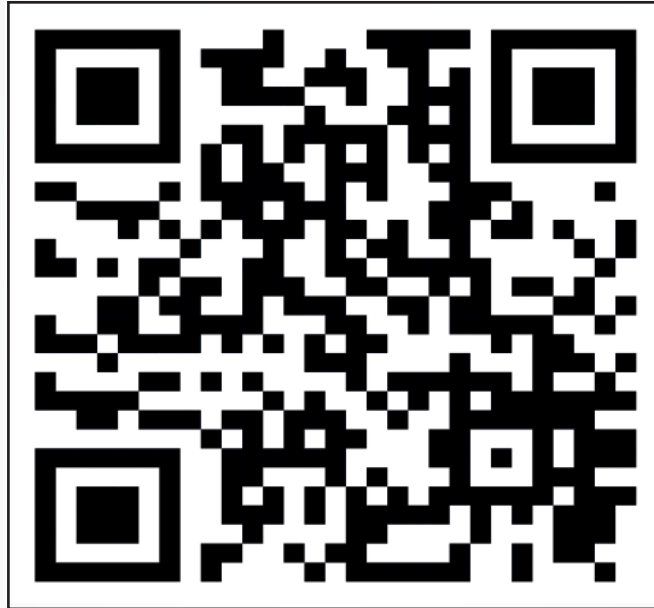

Please scan QR code for  
download the application (ANDROID)

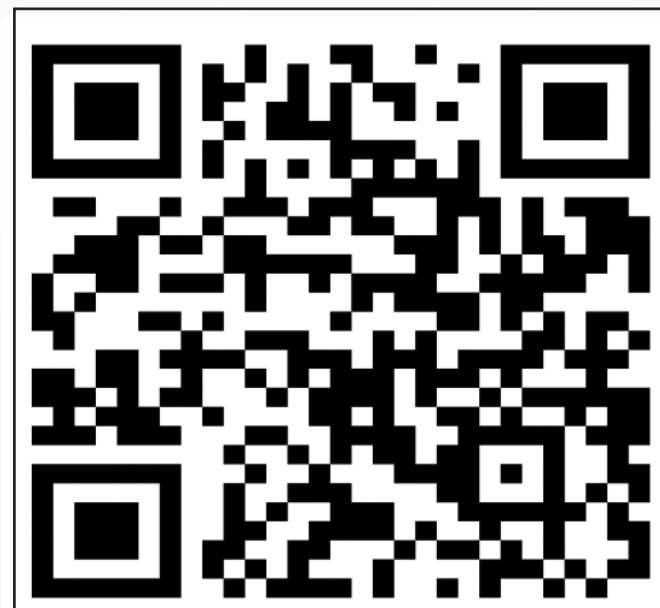

Please scan QR code for  
download the application (IOS)



 [contactus@automatworld.com](mailto:contactus@automatworld.com) |  [www.automatworld.com](http://www.automatworld.com)

 [www.facebook.com/automatindustries](https://www.facebook.com/automatindustries) |  [www.youtube.com/automatindustries](https://www.youtube.com/automatindustries)